

STATE OF HAWAII  
DEPARTMENT OF TRANSPORTATION  
HIGHWAYS DIVISION  
HONOLULU, HAWAII

SPECIAL PROVISIONS, SPECIFICATIONS

AND CONTRACT

FOR

FURNISHING AND DELIVERING METAL GUARDRAILS, POSTS, ELEMENT, END

TREATMENT SYSTEMS, HARDWARE AND IMPACT ATTENUATORS

HIGHWAYS DIVISION

ISLANDS OF OAHU AND MAUI

PROJECT NO. HWY-C-03-23

TABLE OF CONTENTS

Page No.

Notice to Bidders

Special Provisions.....SP-1 – SP-5

Specifications (Matls)

Section 1 Definition and Terms .....1-1 – 1-4

Section 2 Proposal Requirements and Conditions .....2-1 – 2-3

Section 3 Award and Execution of Contract.....3-1 – 3-3

Section 4 Scope of Work .....4-1 – 4-3

Section 5 Control of Work.....5-1 – 5-2

Section 6 Control of Materials .....6-1 – 6-3

Section 7 Legal Relations and Responsibility .....7-1 – 7-4

Section 8 Prosecution and Progress .....8-1 – 8-7

Section 9 Payment.....9-1 – 9-2

Section 10 Furnishing and Delivering Metal Guardrails, Posts,  
Element, end Treatment Systems, Hardware and  
Impact Attenuators .....10-1 – 10-10

Appendices

Appendix A – Standard Plan..... TE-57, TE-57A; Sheets  
M-5A, B-5B, M-2 and M-  
4

Appendix B – Sample - Invoice.....B-1

Appendix C – Sample - Satisfactory Evidence by  
Affidavit for Final Payment .....C-1

Proposal.....PF-1 – PF-5

Page No.

Proposal Schedule.....PF-6 – PF-17

Forms

Sample Contract.....KF-1 – KF-3

## **NOTICE TO BIDDERS**

(Chapter 103D, HRS)

The receiving of SEALED BIDS for FURNISHING AND DELIVERING METAL GUARDRAILS, POSTS, ELEMENT, END TREATMENT SYSTEMS, HARDWARE AND IMPACT ATTENUATORS, PROJECT NO. HWY-C-03-23, ISLANDS OF OAHU AND MAUI, will begin as advertised in HIePRO. Bidders are to register and submit bids through HIePRO only. See the following HIePRO link for important information on registering: <https://hiepro.ehawaii.gov/welcome.html>.

The deadline to submit bids is April 25, 2023, at 2:00 P.M., Hawaii Standard Time. Bids received after said due date and time shall not be considered.

The scope of work consists of furnishing and delivering metal guardrails, posts, element, end treatment systems, hardware and impact attenuators to various Highways District Offices on the islands of Oahu and Maui, on an “as-needed” basis.

ALL requests for information (RFI) shall be received in writing via HIePRO prior to the Question Due Date in General Information of the HIePRO solicitation. Questions received after the deadline will not be addressed. Verbal requests for information will not receive a response.

Any protest of this solicitation shall be submitted in writing to the Director of Transportation, in accordance with §103D-701, HRS and §3-126, HAR.

Campaign contributions by State and County Contractors. Contractors are hereby notified of the applicability of Section 11-355, HRS, which states that campaign contributions are prohibited from specified State or county government contractors during the term of the contract if the contractors are paid with funds appropriated by a legislative body. For more information, contact the Campaign Spending Commission at (808) 586-0285.

The U.S. Department of Transportation Regulation entitled “Nondiscrimination in Federally-Assisted Programs of the U.S. Department of Transportation,” Title 49, Code of Federal Regulations (CFR), Part 21 is applicable to this project. Bidders are hereby notified that the Department of Transportation will affirmatively ensure that the contract entered into pursuant to this advertisement will be awarded to the lowest responsible bidder without discrimination on the grounds of race, color, national origin or sex (as directed by 23 CFR Part 200).

For additional information, contact Jake Dickman, by phone at (808) 587-2189 or email at [jake.j.dickman@hawaii.gov](mailto:jake.j.dickman@hawaii.gov) or Michelle Kwan, by phone at (808) 587-2186 or email at [michelle.s.kwan@hawaii.gov](mailto:michelle.s.kwan@hawaii.gov).

The State reserves the right to reject any or all proposals and to waive any defects in said proposals for the best interest of the public.



---

ROBIN K. SHISHIDO  
Highways Deputy Director

STATE OF HAWAII  
DEPARTMENT OF TRANSPORTATION  
HIGHWAYS DIVISION  
HONOLULU, HAWAII

SPECIAL PROVISIONS

## SPECIAL PROVISIONS

These specifications contained herein are amended as follows:

A. SECTION 1 – DEFINITION AND TERMS shall be amended as follows:

1. 1.33 SUBCONTRACTOR shall be amended in its entirety to read as follows:

“1.33 SUBCONTRACTOR – An individual, partnership, firm, corporation, or joint venture, or other legal entity, as licensed or required to be licensed under Chapter 444, Hawaii Revised Statutes, as amended, which enters into an agreement with the Contractor to perform a portion of the work.”

2. 1.38 WORKING DAY shall be amended in its entirety to read as follows:

“1.38 WORKING DAY – Every day, except Saturdays, Sundays, and State holidays as applicable and as observed.

Normal State holidays are as follows:

New Year’s Day (The first day of January)  
Dr. Martin Luther King, Jr. Day (The third Monday in January)  
President’s Day (The third Monday in February)  
Prince Jonah Kuhio Kalaniana’ole Day (The twenty-sixth day in March)  
Good Friday (The Friday preceding Easter Sunday)  
Memorial Day (The last Monday in May)  
King Kamehameha I Day (The eleventh day in June)  
Independence Day (The fourth day in July)  
Statehood Day (The third Friday in August)  
Labor Day (The first Monday in September)  
General Election Day (The first Tuesday in November following the first Monday of even numbered years)  
Veteran’s Day (The eleventh day in November)  
Thanksgiving (The fourth Thursday in November)  
Christmas (The twenty-fifth day in December)

State Holiday schedules can be obtained online at:

<http://dhrd.hawaii.gov/state-observed-holidays/>”

3. Add the following new subsection:

“1.39 ENGINEER – The respective District Engineer, acting directly or through their duly authorized representatives, who are responsible for District engineering supervision of construction and other highway matters.”

“1.40 STANDARD SPECIFICATIONS – The Hawaii Standard Specifications for Road and Bridge Construction, 2005, Highways Division, Department of Transportation, including any amendments. Log on to:

<http://hidot.hawaii.gov/highways/s2005-standard-specifications/>

to review the 2005 Standard Specifications and their applicable amendments/Special Provisions.”

“1.41 STANDARD PLANS – The Standard Plans, 2008, issued by the State of Hawaii, Department of Transportation, Highways Division, Design Branch, as amended, revised or updated.

The Standard Plans are available from the Department of Transportation, Highways Division. For information, log on to:

<https://hidot.hawaii.gov/highways/s2005-standard-specifications/>

B. SECTION 2 – PROPOSAL REQUIREMENTS AND CONDITIONS shall be amended as follows:

1. 2.3 DELIVERY OF PROPOSALS shall be amended in its entirety to read as follows:

“2.3 DELIVERY OF PROPOSALS – The bidder shall submit the proposal in HiePRO. Bids received after said date and time shall not be considered. Original bid documents do not have to be submitted. Award will be made based on proposals submitted via HiePRO.”

2. 2.4 WITHDRAWAL OF PROPOSALS shall be amended in its entirety to read as follows:

“2.4 WITHDRAWAL OF PROPOSALS – A bidder may withdraw or revise a proposal after bidder submits the proposal in HiePRO. Withdrawal or revisions of a proposal must be completed before the time set receiving of bids.”

3. 2.5 PUBLIC OPENING OF PROPOSALS is not applicable.

4. 2.8 OUT OF STATE BIDDERS shall be amended by adding the following to the end of the subsection:

“Successful out-of-state bidders shall, after ten (10) days from the Notice to Proceed, provide a name and phone number of the Contractor’s Technical Representative who will be responsible in assisting the recipient districts

throughout the duration of the contract. Corporations must be registered to do business in the State of Hawaii. For information on business registration, please call Department of Commerce and Consumer Affairs at (808) 586-2545 or log on to: <http://www.hawaii.gov/dcca/areas/breg>.”

C. SECTION 3 – AWARD AND EXECUTION OF CONTRACT shall be amended as follows:

1. 3.1 AWARD OF CONTRACT shall be amended by adding the following to the end of the subsection:

“The State reserves the right to reject any and all proposal and to waive any defects as may be deemed to be in the best interest of the public. Any bid lacking a unit price or amount shall disqualify the bidder.”

2. 3.4 REQUIREMENT OF CONTRACT BOND shall be deleted in its entirety.

D. SECTION 4 – SCOPE OF WORK shall be amended as follows:

1. 4.6 VARIATION IN QUANTITY shall be replaced in its entirety to read as follows:

“4.6 CONTRACT TO BE INDEFINITE QUANTITY – The requirement for materials to be furnished by the Contractor will be on an “as-needed” basis as called for in these Specifications at the applicable unit price bid during the term of this contract and in such numbers as may be required by the State. The quantities specified in the contract is an estimate and does not signify a minimum or maximum amount. The unit bid price indicated by the Contractor shall be applicable and binding under the terms of this contract. Payment for services will be made by Purchase Order.”

E. SECTION 6 – TRADE NAMES AND ALTERNATES shall be amended as follows:

1. 6.2.A QUALIFICATION BEFORE BID OPENING shall be amended by replacing the last sentence of the first paragraph as follows:

“The bidder shall submit a request to the Department for review and approval at the earliest date possible. Requests shall be submitted via email to the Contact person listed in HIePRO for the solicitation and also posted as a question in HIePRO under the question/answer tab referencing the email with the request, but in any event, such request must be received at the Construction and Maintenance Branch office, Room 404, Department of Transportation – Highways Division,

869 Punchbowl Street, Honolulu, Hawaii, 96813 not later than ten (10) days before the bid opening date, not including the bid opening date.”

F. SECTION 8 – PROSECUTION AND PROGRESS shall be amended as follows:

1. 8.1 PROGRESS OF WORK shall be amended by adding the following paragraph to the end of the subsection:

“The Contractor shall diligently prosecute the work to completion within the time limit specified in the proposal. The Notice to Proceed will indicate the date the Contractor is expected to begin the work and from which date contract time will be charged. The Contractor shall give his personal attention to the fulfillment of the contract and shall keep the work under his control.

If the materials fail to meet specification requirements, the Contractor will be notified of such and the material will be rejected. The Contractor shall replace the rejected material with those that meet the specification requirements, and liquidated damages in accordance with the 8.2 Liquidated Damages of the Special Provisions, will be assessed against him for late delivery any time after the required completion date. Time taken to perform the material sampling and testing, however, will not be charged against the Contractor.”

2. 8.2 LIQUIDATED DAMAGES shall be amended by as follows:

- a. Add the following to the end of the subsection:

“1/4 of 1% of the total contract price of each item for each calendar day for failure to deliver the items within the delivery period. The assessed amount, however, will be no less than TEN DOLLARS (\$10.00) for each bid item for each and every calendar day.”

- b. The following shall replace the first sentence of the second paragraph:

“Delivery extension shall be considered only with written notice **prior to delivery deadline**. Written notice requesting extension will not be considered without a copy of the factory order, factory confirmation of order and without documents substantiating that the cause(s) for delay is, in fact, beyond the control of the Contractor. The State shall be the sole judge of whether such delay is truly beyond the control of the Contractor and whether an extension will be granted.”

G. SECTION 9 – PAYMENT shall be amended as follows:

1. 9.2 PROGRESS PAYMENTS shall be amended by adding the following to the end of the subsection:

“D. Deductions, as applicable, shall be included in the invoices as subtotal(s) and labeled as either (1) and/or (2) below:

- (1) Retainage as specified in Section 9.2 Progress Payments, of the Specifications.
- (2) Liquidated Damages, as specified in Section 8.2 of the Special Provisions.

After the delivery of materials, the Contractor shall forward the required invoice as specified in Section 9.2 Progress Payments, of the Specifications, to the recipient district as applicable and as indicated below for approval of payments.

District Engineer – Oahu District Highways Division – State DOT Kakoi Baseyard 727 Kakoi Street Honolulu, Hawaii 96819	District Engineer – Maui District Highways Division – State DOT Kahului Baseyard 650 Palapala Drive Kahului, Hawaii 96732
--	---

The Engineer shall issue a Purchase Order for payments to pay for all furnished, delivered, and accepted materials.

*Pursuant to the State of Hawaii Department of Transportation (DOT) Procurement Delegation signed by the DOT Director on October 8, 2012, Purchase Orders may not be issued or used unless there is a Purchase Requisition signed by an authorized person.”*

STATE OF HAWAII  
DEPARTMENT OF TRANSPORTATION  
HIGHWAYS DIVISION  
HONOLULU, HAWAII

SPECIFICATIONS

## SECTION 1 - DEFINITION AND TERMS

Whenever the following pronouns are used in these specifications, or in any documents or instruments where these specifications govern, the intent and meaning shall be interpreted as follows:

1.1 ADDENDA - A written document which may be issued by the Director during the bidding period involving changes to the specifications and plans, if any, which shall be considered and made a part of the contract.

1.2 AIRPORTS DIVISION - Airports Division, Department of Transportation, State of Hawaii.

1.3 AWARD - The written acceptance of a proposal by the State.

1.4 BIDDER - Any individual, partnership, corporation or other legal entity, or combination thereof, submitting a proposal for the work contemplated, acting either directly or through a duly authorized representative.

1.5 CALENDAR DAY - Every day shown on the calendar. If no designation of calendar or working day is made, "day" shall mean calendar day.

1.6 CHANGE ORDER - A written order issued by the Director to the Contractor requiring the contract work to be performed in accordance with a change or changes that may involve an adjustment in contract time and price or requiring performance of any unforeseen work essential to complete the contract.

1.7 CONTRACT - The written agreement between the State and the Contractor setting forth the obligations of the parties thereunder, including, but not limited to, the performance of the work, the furnishing of labor and materials, and the basis of payment.

The contract includes the (1) notice to bidders, (2) proposal, (3) contract form and contract bond, (4) specifications, (5) special provisions and plans, if any, (6) addenda, (7) notice to proceed, and (8) change orders and agreements that are required to complete the work, all of which constitute one instrument.

1.8 CONTRACT BOND - The approved form of security, executed by the Contractor and its Surety or Sureties, guaranteeing the completion of the work in accordance with the terms of the contract, and guaranteeing full payment of all claims for labor, materials, and supplies used or incorporated in the work.

1.9 CONTRACT TIME - The number of working days or calendar days allowed for completion of the contract, including authorized time extensions.

If a calendar date is specified as the date of completion in lieu of the number of working days or calendar days, the contract shall be completed by that date.

In case the contract is for a specified period of time, the contract time shall be for said specified period of time.

1.10 CONTRACTOR - The individual, partnership, corporation or other legal entity, or combination thereof, contracting with the State for performance of the prescribed work.

1.11 DEPARTMENT - The State Department of Transportation.

1.12 DIRECTOR - The Director of Transportation, acting either directly or through the Director's duly authorized representative.

1.13 EQUAL OR APPROVED EQUAL - Whenever this term is used in the specifications and plans, if any, it means a brand or article pre-qualified in accordance with Section 6.2 Trade Names and Alternates and which may be used in place of the one specified.

1.14 H.A.R. or HAR - Hawaii Administrative Rules.

1.15 H.R.S. or HRS - Hawaii Revised Statutes.

1.16 HARBORS DIVISION - Harbors Division, Department of Transportation, State of Hawaii.

1.17 HIGHWAYS DIVISION - Highways Division, Department of Transportation, State of Hawaii.

1.18 HOLIDAYS - The days which are set apart and established as State holidays pursuant to Section 8-1, H.R.S.

1.19 INSPECTOR - The Director's authorized representative assigned to make detailed inspections of contract performance and materials supplied.

1.20 NOTICE TO BIDDERS - The public announcement, as required by law, inviting proposals for the work to be performed or materials to be furnished.

1.21 NOTICE OF FINAL ACCEPTANCE - Written notice from the Director to the Contractor that the entire contract has been completed in all respects in accordance with the specifications and plans, if any, and any changes thereof previously approved by the Director.

1.22 NOTICE TO PROCEED - Written notice from the Director to the Contractor advising the Contractor of the date on which he is to begin the prosecution of the work.

1.23 PLANS - The contract drawings approved by the Director which show the location, character, dimensions and details of the work to be done and shall be a part of the contract.

1.24 PROCUREMENT OFFICER - The Director's duly authorized representative including project managers, project engineers and contract administrators assigned to prepare, evaluate and administer contracts for the purchasing of goods and services.

1.25 PROPOSAL (OR BID) - The offer of a bidder, on the prescribed form, to perform the work and to furnish the labor and materials at the prices quoted.

1.26 PROPOSAL FORM - The approved format prepared by the Department or a facsimile thereof on which bids for the work must be prepared and submitted. (Reasonable facsimile acceptable for bidding.)

1.27 PROPOSAL GUARANTY - The security furnished with a proposal to guarantee that the bidder will enter into the contract and furnish all other requirements if the bidder's proposal is accepted.

1.28 QUALIFICATION QUESTIONNAIRE - The specified forms on which the bidder shall furnish required information as to the bidder's ability to perform and finance the work.

1.29 S.L.H. or SLH - Session Laws of Hawaii.

1.30 SPECIAL PROVISIONS - Revisions to the specifications. The specific clauses setting forth conditions or requirements peculiar to the project under consideration which are not thoroughly or satisfactorily stipulated in these specifications.

1.31 SPECIFICATIONS - The directions, provisions, and requirements pertaining to the method and manner of performing the work and to the quantities and qualities of materials to be furnished under the contract.

1.32 STATE - The State of Hawaii.

1.33 SUBCONTRACTOR - An individual, partnership, corporation, other legal entity, or any combination thereof, that enters into an agreement with the Contractor to perform a portion of the work for the Contractor.

1.34 SUPERINTENDENT - The Contractor's representative who is responsible for and in charge of the work.

1.35 SURETY - The corporation, partnership or individual, other than the Contractor, executing a bond furnished by the Contractor and guaranteeing performance by the Contractor.

1.36 TITLES (OR HEADINGS) - The titles or headings of the Sections herein are intended for convenience of reference and shall not be considered as having any bearing on their interpretation. Unless otherwise indicated, whenever the word "Section" is used, reference is being made to a Section in these specifications.

1.37 WORK - The furnishing of all labor, materials, equipment, and other incidentals necessary or convenient for the successful completion of the project and the execution of all the duties and obligations imposed by the contract.

1.38 WORKING DAY - Any day, except Saturdays, Sundays and State holidays.

## SECTION 2 - PROPOSAL REQUIREMENTS AND CONDITIONS

2.1 PROPOSAL FORMS - All proposals shall be made on forms furnished by the Department. All proposals shall give the prices proposed in the spaces provided and shall be signed by the bidder, who shall fill out all blanks in the proposal form as therein required.

2.2 REJECTION OF PROPOSALS CONTAINING ALTERATIONS, ERASURES, OR IRREGULARITIES - Proposals may be rejected if they show any alterations of form, additions not called for, conditional bids, incomplete bids, erasures, or irregularities of any kind.

When proposals are signed by any agent, other than the officer or officers of a corporation authorized to sign contract on its behalf or a member of copartnership, a Power of Attorney must be on file with the Department prior to opening bids or shall be submitted with the proposal; otherwise, the proposal may be rejected as irregular and unauthorized.

Members of a joint venture may be requested to supply the Department with a copy of their joint venture agreement or each member of the joint venture may be required to sign the proposal.

2.3 DELIVERY OF PROPOSALS - Each proposal shall be placed, together with the proposal guaranty, when required, in an envelope and sealed and so marked as to indicate the identity of the project, the name and address of the bidder, and other required information and then delivered as indicated in the Notice to Bidders. Proposals will be received up to the time fixed in the Notice to Bidders for the opening of bids.

2.4 WITHDRAWAL OF PROPOSALS - Any proposal may be withdrawn at any time prior to the time fixed in the Notice to Bidders for the opening of proposals upon the filing of a written request therefor with the Department, executed by the bidder or his duly authorized representative. The withdrawal of a proposal shall not preclude a bidder from submitting a new proposal.

2.5 PUBLIC OPENING OF PROPOSALS - Proposals will be opened and read publicly at the time and place indicated in the Notice to Bidders. Bidders or their authorized agents are invited to be present.

2.6 DISQUALIFICATION OF BIDDERS - Any of the following reasons may be considered as being sufficient grounds for the disqualification of a bidder and the rejection of his proposal or proposals.

A. More than one proposal for the same work from an individual, firm, or corporation under the same or different name.

B. Evidence of collusion among bidders. Participants in such collusion will receive no recognition as bidders for any future work of the Department until such participant shall have been reinstated as a qualified bidder.

C. Evidence of assistance from a person who has been an employee of the agency within the preceding two years and who participated while in State office or employment in the matter with which the contract is directly concerned, pursuant to Section 84-15, HRS.

D. Lack of proposal guaranty.

E. Unsigned proposal or proposal not signed in ink by person or persons legally authorized to submit a proposal on behalf of the bidder.

2.7 MATERIAL GUARANTY - The bidder may be required to furnish a complete statement of the origin, composition and manufacture of any or all materials to be used in the prosecution of the work, together with samples. Such samples may be subjected to tests to determine their quality and fitness for the work.

2.8 OUT-OF-STATE BIDDERS - Pursuant to Section 103D-1008, Hawaii Revised Statutes, on out-of-state purchases where the bidder or vendor is an out-of-state vendor, not doing business in the State, the bid price of such out-of-state vendor, for the purpose of determining the lowest price bid, shall be increased by the applicable retail rate of general excise tax and the applicable use tax. The lowest responsible bidder, taking into consideration the above increases, shall be awarded the contract, but the contract amount of any contract awarded shall be the amount of the bid offered and shall not include the amount of said increases.

Such increases will not be applied in case an out-of-state vendor specifies in its bid that its bid price includes said general excise tax; the bidder will be required to pay said general excise tax and use tax in case the bidder is awarded the contract.

2.9 TAX REQUIREMENTS - Work to be done under this contract is a taxable transaction and the bidder receiving the award for this work will be required to pay the State of Hawaii General Excise Tax (GET) and the State of Hawaii use Tax.

Additional information regarding the tax rates may be obtained from the Department of Taxation (DOTAX) website at <http://tax.hawaii.gov/geninfo/countysurcharge/>

If awardee is an out-of-state bidder not holding a Hawaii GET License, the awardee will have to obtain a Hawaii GET License and pay all taxes due to obtain a tax clearance required before final contract payment is made by the State.

To obtain the tax clearance applications, see subsection 3.1.A. Tax Clearance of these Specifications.

Vendors may apply for either a regular or a one-time GET License. Information on applying for a GET License may be found at <http://tax.hawaii.gov/geninfo/get/>

SECTION 3 - AWARD AND EXECUTION OF CONTRACT

3.1 AWARD OF CONTRACT - The State reserves the right to reject any and all proposals and to waive any defects as may be deemed to be in the best interest of the public.

The award of contract, if it be awarded, will be made within sixty (60) calendar days after the opening of bids to the lowest responsive and responsible bidder whose proposal complies with all the prescribed requirements. The successful bidder will be notified, by letter mailed to the address shown on its proposal, that its proposal has been accepted and it has been awarded the contract.

**Requirement for award.** To be eligible for award, the apparent low Bidder will be contacted to submit copies of the documents listed below to demonstrate compliance with Section 103D-310(c), HRS. The documents should be submitted to the Department as soon as possible. If a valid certificate/clearance is not submitted on a timely basis for award of a contract, a Bidder otherwise responsive and responsible may not receive the award.

**A. Tax Clearance.**

Pursuant to §103D-310(c), 103-53 and 103D-328, HRS, the successful bidder shall be required to submit a certified copy of its tax clearance issued by the Hawaii State Department of Taxation (DOTAX) and the Internal Revenue Service (IRS) to demonstrate its compliance with Chapter 237, HRS. A tax clearance is valid for six (6) months from the most recent approval stamp date on the tax clearance and must be valid on the bid's first legal advertisement date or any date thereafter up to the bid opening date.

FORM A6, TAX CLEARANCE CERTIFICATE, is available at the following website:

<http://www.hawaii.gov/tax/>

To receive DOTAX Forms by fax or mail, phone (808)587-7572 or 1-800-222-7572.

The application for the Tax Clearance Certificate is the responsibility of the bidder, and must be submitted directly to the DOTAX or IRS. The approved certificate may then be submitted to the Department.

**B. DLIR Certificate of Compliance.**

Pursuant to §103D-310(c), HRS, the successful bidder shall be required to submit a copy (faxed copies are acceptable) of its approved Certificate of Compliance issued by the Hawaii State Department of Labor and Industrial Relations (DLIR) to demonstrate its compliance with unemployment insurance (Chapter 383, HRS), workers' compensation (Chapter 386, HRS), temporary disability insurance (Chapter 392, HRS), and prepaid health care (Chapter 393, HRS). The certificate is valid for six (6) months from the most recent approval stamp date on the certificate and must be valid on the bid's first legal advertisement date or any date thereafter up to the bid opening date. For certificates which receive a "pending" approval stamp, a DLIR approval stamp is required prior to the issuance of the Notice to Proceed.

FORM LIR#27, APPLICATION FOR CERTIFICATE OF COMPLIANCE WITH SECTION 3-122-112, HAR, is available at the following website:

[www.hawaii.gov/labor](http://www.hawaii.gov/labor)

More information is available by calling the DLIR Unemployment Insurance Division at (808) 586-8926.

Inquiries regarding the status of a LIR#27 Form may be made by calling the DLIR Disability Compensation Division at (808)586-9200.

The application for the Certificate of Compliance is the responsibility of the bidder, and must be submitted directly to the DLIR. The approved certificate may then be submitted to the Department.

**C. DCCA Certificate of Good Standing.**

Pursuant to §103D-310(c), HRS, the successful bidder shall be required to submit a copy (faxed copies are acceptable) of its approved Certificate of Good Standing issued by the Hawaii State Department of Commerce and Consumer Affairs (DCCA), Business Registration Division (BREG) to demonstrate that it is either:

- (1) incorporated or organized under the laws of the State; or
- (2) registered to do business in the State as a separate branch or division that is

capable of fully performing under the contract.

A Certificate of Good Standing is valid for six (6) months from the approval date on the certificate and must be valid on the bid's first legal advertisement date or any date thereafter up to the bid opening date. A Hawaii business that is a sole proprietorship, is not required to register with the BREG, and therefore not required to submit a Certificate of Good Standing. Bidders are advised that there are costs associated with registering and obtaining a Certificate of Good Standing from the DCCA.

To purchase a CERTIFICATE OF GOOD STANDING, go to On-Line Services at the following website:

[www.hawaii.gov/dcca/](http://www.hawaii.gov/dcca/)

The application for the Certificate of Good Standing is the responsibility of the bidder, and must be submitted directly to the DCCA. The approved certificate may then be submitted to the Department.

3.2 CANCELLATION OF AWARD - The State reserves the right to cancel the award of any contract any time before the execution of said contract by all parties without any liability to the successful bidder or any other bidder.

3.3 EXECUTION OF CONTRACT - The contract shall be executed by the successful bidder and returned, together with the contract bonds, when required, within ten (10) days after the award of the contract or within such further time as the Director may allow after the bidder has received the contract for execution.

Pursuant to Section 103D-309, H.R.S., the contract shall not bind the State in any way unless said contract has been fully and properly executed by all the parties thereto and the Comptroller has endorsed thereon a certificate that there is available an unexpended appropriation over and above all outstanding contracts, sufficient to cover the amount required by the contract.

3.4 FAILURE TO EXECUTE CONTRACT - Failure to execute the contract and file acceptable bonds, when required, within ten (10) days after the award of the contract, or within such further time as the Director may allow, shall be cause for the cancellation of the award and the forfeiture of the proposal guaranty. Award of the contract may then be made to the next lowest responsible bidder.

## SECTION 4 - SCOPE OF WORK

4.1 WORK TO BE DONE - The work to be done is described in the Section(s) following Section 9 of these specifications.

4.2 PERFORMANCE OF WORK - The Contractor shall employ, so far as possible, such methods and means in carrying out his work so as not to cause any interruption, disturbance, or interference with the public.

In case the Contractor is performing work in a building, the Contractor shall conduct the work in such a manner so as not to cause any interruption, disturbance, or interference with the business activities of the tenants in the building.

4.3 EXTRA WORK - New and unforeseen items of work will be classed as extra work when they cannot be covered by any of the various items for which there is a bid price.

### 4.4 CHANGES AND CLAIMS FOR ADJUSTMENT

A. Change order. By a written order, at any time, and without notice to any surety, the procurement officer may, subject to all appropriate adjustments, make changes within the general scope of this contract in any one or more of the following:

1. Drawings, designs, or specifications, if the goods to be furnished are to be specially manufactured for the State in accordance therewith;
2. Method of shipment or packing;
3. Place of delivery;
4. Changes in the work within the scope of the contract; or
5. Changes in the time of performance of the contract that do not alter the scope of work.

B. Adjustments of price or time for performance. If any change order increases or decreases the contractor's cost of, or the time required for, performance of any part of the work under this contract, whether or not changed by the order, an adjustment shall be made and the contract modified in writing accordingly. Any adjustment in contract price made pursuant to this clause shall be determined in accordance with the price adjustment clause of this contract. Failure of the parties to agree to an adjustment shall not excuse the contractor from proceeding with the contract as changed, provided that the procurement officer promptly and duly make the provisional adjustments in payment or time for performance as may be reasonable. By proceeding with the work, the contractor shall not be deemed to have

prejudiced any claim for additional compensation, or an extension of time for completion.

C. Time period for claim. Within thirty (30) days after receipt of a written change order under subsection (a) unless the period is extended by the procurement officer in writing, the contractor shall file notice of intent to assert a claim for an adjustment. Later notification shall not bar the contractor's claim unless the State or county is prejudiced by the delay in notification.

D. Claim barred after final payment. No claim by the contractor for an adjustment hereunder shall be allowed if notice is not given prior to final payment under this contract.

E. Other claims not barred. In the absence of a change order, nothing in this clause shall be deemed to restrict the contractor's right to pursue a claim as under the contract or for breach of contract.

#### 4.5 PRICE ADJUSTMENT

Any adjustment in contract price pursuant to a clause in this contract shall be made in one or more of the following ways:

A. By agreement on a fixed price adjustment before commencement of the pertinent performance or as soon thereafter as practicable;

B. By unit prices specified in the contract or subsequently agreed upon;

C. By the costs attributable to the event or situation covered by the clause, plus appropriate profit or fee, all as specified in the contract or subsequently agreed upon;

D. In such other manner as the parties may mutually agree; or

E. In the absence of agreement between the parties, by a unilateral determination by the procurement officer of the costs attributable to the event or situation covered by the clause, plus appropriate profit or fee, all as computed by the procurement officer in accordance with generally accepted accounting principles and applicable sections of chapters 3-123 and 3-126 of the Hawaii Administrative Rules.

#### 4.6 VARIATION IN QUANTITY

Upon agreement of the parties, the quantity of goods or services or both specified in this contract may be increased by a maximum of ten (10) percent provided (1) the unit prices will remain the same except for any price adjustments otherwise applicable and (2) the procurement officer makes a written determination that such an increase will either be more economical than awarding another contract or that it would not be practical to award another contract.

SECTION 5 - CONTROL OF WORK

5.1 AUTHORITY OF DIRECTOR - The Director shall decide all questions which may arise as to the quality or acceptability of materials furnished and work performed, the manner of performance and rate of progress of the work, and compensation for work performed, interpretation of the contract and fulfillment of the contract on the part of the Contractor. The Director shall have authority to enforce and make effective such decisions and orders which the Contractor fails to carry out properly and diligently. The decision of the Director shall be final.

5.2 COORDINATION OF PLANS, SPECIFICATIONS AND SPECIAL PROVISIONS - These specifications, plans, special provisions, and all supplementary documents are essential parts of the contract, and a requirement occurring in one is as binding as though occurring in all. They are intended to be complementary and to describe and provide for a complete work.

5.3 CLAIMS AND DISPUTES - The Contractor may give notice in writing to the procurement officer for claims that extra compensation, damages, or an extension of time for completion is due the Contractor for one or more of the following reasons:

- A. Requirements not clearly covered in the contract, or not ordered by the procurement officer as an extra work;
- B. Failure between the State and the Contractor to agree to an adjustment in price for a contract change order issued by the State; or
- C. An action or omission on the part of the procurement officer requiring performance changes within the scope of the contract.

The Contractor shall continue with performance of the contract in compliance with the directions or orders of the procurement officer, but by so doing, the Contractor shall not be deemed to have prejudiced any claim for additional compensation, damages, or an extension of time for completion; provided:

- A. The notice in writing be given:
  - 1. Before the commencement of the work involved, if at that time the Contractor knows of such requirements or the occurrence of such actions or omissions; or
  - 2. Within thirty (30) calendar days after the

Contractor knows of such requirements or the occurrence of such action or omission if the Contractor did not have such knowledge before the commencement of the work; or

3. Within thirty (30) calendar days after receipt of the written contract change order that was not agreed upon by both parties; or

4. Within such further time as may be allowed by the procurement officer in writing.

B. The notice shall clearly state the Contractor's intention to make claim and the reasons why the Contractor believes that additional compensation, changes or an extension of time may be remedies to which the Contractor is entitled; and afford the procurement officer every facility for keeping records of the actual cost of work. Failure on the part of the Contractor to give such notification or to afford the procurement officer proper facilities for keeping strict account of actual cost shall constitute waiver of the claim for such extra compensation. The filing of such notice by the Contractor and the keeping of costs by the procurement officer shall not in any way be construed to prove the validity of the claim.

The procurement officer will review the notice and render a decision. The procurement officer's decision shall be final and conclusive unless, within thirty (30) calendar days from the date of the decision, the Contractor mails or otherwise furnishes a written appeal to the Director. The decision of the Director shall be final. Later notification of such claims shall not bar the Contractor's claim unless the State is prejudiced by the delay in notification. No claim by the Contractor for an adjustment hereunder shall be allowed if notice is not given before final payment under this contract. Any adjustment in the contract price made pursuant to this clause shall be determined according to Section 4.5 - Price Adjustment.

The provisions of this Section shall not be construed as establishing any claims contrary to the terms of Section 4.4 - Changes and Claims for Adjustment.

Nothing herein contained, however, shall excuse the Contractor from compliance with any rules of law precluding any state officers and any Contractors from acting in collusion or bad faith in issuing or performing contract change orders which are clearly not within the scope of the contract.

SECTION 6 - CONTROL OF MATERIAL AND EQUIPMENT

6.1 DEFECTIVE MATERIALS - All materials not conforming to the requirements of these specifications or the special provisions shall be considered defective and all such materials, whether in place or not, shall be rejected. They shall be removed immediately from the site of the work, unless otherwise permitted by the Director. No rejected materials, the defects of which have been subsequently corrected, shall be used until approval in writing has been given by the Director. Upon failure on the part of the Contractor to comply promptly with any order to remove and replace defective materials, the Director may remove and replace defective material and to deduct the cost of removal and replacement from any monies due or to become due the Contractor.

6.2 TRADE NAMES AND ALTERNATES - For convenience in designation on the plans or in the specifications, certain equipment or articles or materials may be designated under a trade name or the name of a manufacturer and its information catalogue. The use of alternate equipment or an article or material which is of equal quality and of the required characteristics for the purposes intended will be permitted, subject to the written approval of the Director, in accordance with the following requirements:

A. QUALIFICATION BEFORE BID OPENING - When the specifications and/or plans specify one or more manufacturer's brand names of materials or equipment to indicate a quality, style, appearance, or performance, the bidder will be assumed to have based its bid on one of the specified named products, except where such proprietary product are specified, alternate brands may be qualified if found equal or better by the Director. Bidders requesting qualification of alternate proprietary products must submit a request to the Director for review and approval at the earliest date possible, but in any event, such request must be received at the Contracts office not later than ten (10) days before the bid opening date, not including the bid opening date.

It shall be the responsibility of the bidder to submit sufficient evidence based upon which a determination can be made by the Director that the alternate brand is qualified. The evidence shall be transmitted with a covering letter which shall list the evidence submitted and the items for which the substitution is requested.

If the evidence accompanying a request for substitution is insufficient to qualify a particular

model, the request shall be denied provided that further evidence may be submitted to qualify the item five (5) days prior to the bid opening date if the initial request was made prior to the deadline set above.

B. SUBSTITUTION AFTER BID OPENING - Substitution of material or equipment will not be allowed after the bid opening date except under the following unforeseen circumstances:

1. If a specified or pre qualified item is delayed by a lengthy strike in the factory or other unforeseeable contingency beyond the control of the Contractor which would cause an abnormal delay in the project completion.
2. If a specified or pre qualified item is found to be unusable due to change or other circumstances.
3. If the Contractor is willing to provide a more recently developed or manufactured item of material or equipment of the same manufacturer which the Director determines to be equal or better than the one specified or pre-qualified.

A substitution request, regardless of reason, shall be fully explained in writing by the Contractor and shall include its justification for said request, the quantities and unit prices involved, quotations and such other documents as are deemed necessary to support the request. Any savings in cost will accrue to the State and any additional cost for the substituted items will be paid by the Contractor.

The burden of proof as to the comparative quality and suitability of alternate equipment, articles, or materials shall be upon the bidder or Contractor and bidder or Contractor shall furnish, at its own expense, all information necessary or related thereto as required by the Director. The Director shall be the sole judge as to the comparative quality and suitability of alternate equipment, articles or materials and the Director's decisions shall be final.

The above shall not be construed to mean that substitution for brand name specified materials and equipment will be allowed; the Director reserves the right to deny any request he deems irregular or not in the best interest of the State.

6.3 ASSIGNMENT OF ANTITRUST CLAIMS FOR OVERCHARGES FOR GOODS AND MATERIALS PURCHASED

A. Vendor and purchaser recognize that in actual economic practice, overcharges resulting from antitrust violations are in fact usually borne by the purchaser. Therefore, vendor hereby assigns to purchaser any and all claims for such overcharges as to goods and materials purchased in connection with this order or contract, except as to overcharges which result from antitrust violations commencing after the price is established under this order or contract and which are not passed on to the purchaser under an escalation clause.

B. Contractor and owner recognize that in actual economic practice, overcharges resulting from antitrust violations are in fact usually borne by the owner. Therefore, contractor hereby assigns to owner any and all claims for such overcharges as to goods and materials purchased in connection with this order or contract, except as to overcharges which result from antitrust violations commencing after the price is established under this order or contract and any change order. In addition, contractor warrants and represents that each of its first tier suppliers and subcontractors shall assign any and all such claims to owner, subject to the aforementioned exception.

SECTION 7 - LEGAL RELATIONS AND RESPONSIBILITY

7.1 LAWS TO BE OBSERVED - The Contractor shall comply with all federal, state, city and county laws, ordinances, rules and regulations which in any manner affect those engaged or employed in the work, the materials used in the work, and the conduct of the work. Any reference to such laws, ordinances, rules and regulations shall include any amendments thereto effective as of the date of the call for sealed proposals.

The Contractor shall hold harmless, indemnify, defend and where appropriate, insure the State, its officers, agents and employees against any claim or liability arising from or based on the violation of any such laws, ordinances, rules or regulations. If any discrepancy or inconsistency is discovered in the contract for the work in relation to any law, ordinance, rule, regulation, order or decree, the Contractor shall forthwith report the same to the Director in writing.

7.2 PERMITS AND LICENSES - The Contractor shall procure all permits and licenses, pay all charges and fees, and give all notices necessary and incident to the due and lawful prosecution of the work.

7.3 PATENTS - The Contractor shall assume all costs arising from the use of patented materials, equipment, devices, or processes used on or incorporated in the work, and shall hold harmless, indemnify, defend and where appropriate, insure the State, its officers, agents and employees from all suits at law or actions of every nature, for or on account of the use of any patented materials, equipment, devices or processes.

7.4 RESPONSIBILITY FOR INJURY AND DAMAGE - The State, its officers, agents and employees shall not be held accountable in any manner for any loss or damage to the work or any part thereof, or for any of the materials and equipment used or employed in performing the work, or for any injury to any person or persons either workers or the public, or for any damage to property caused by the Contractor or its workers or any one employed by the Contractor. The Contractor shall be responsible for any liability imposed by law for any injury to any person or any damage to property resulting from defects or obstructions or from any cause whatsoever during the progress of the work or at any time before its completion and final acceptance. The acceptance of the completed work of the Contractor by the Director shall not relieve the Contractor from any liability which may have accrued or may accrue as a result of the performance of the work by the Contractor. The Contractor shall hold harmless, indemnify, defend and where appropriate, insure the State, its officers, agents and employees, from all suits or actions of every name, kind and description, brought for or on account of

any injuries or damages sustained by any persons or property caused by the Contractor, its servants or agents, or by or on account of any act or omission of the Contractor or its servants or agents, regardless of whether such actions or any claim is brought against them or any one of them before or after the final acceptance of the work. In addition to any remedy authorized by law, the State may withhold payment of any money due to Contractor as shall be reasonable until disposition has been made of any suits or claims for injuries or damages.

It is not the intention of the parties to this contract to make the public or any member thereof a third party beneficiary hereunder, or to authorize anyone not a party hereto to maintain a suit for personal injuries or property damage based on a contract theory of liability. In any event, the Contractor shall hold harmless, indemnify, defend and where appropriate, insure the State from suits and claims for personal injuries or property damage where such injuries or damage are caused by the negligent acts or omissions of the Contractor, its agents or employees.

7.5 COOPERATION BETWEEN CONTRACTORS - Where two or more Contractors are employed on related or adjacent work, each shall conduct its operations in such a manner as not to cause any unnecessary delay or hindrance to the other.

7.6 CONTRACTOR'S RESPONSIBILITY FOR WORK - Until the acceptance of the contract, the Contractor shall have the charge and care thereof and shall bear the risk of injury or damage to any part thereof by the action of the elements or from any other cause, whether arising from the execution or from the non-execution of the work. The Contractor shall rebuild, repair, restore, and make good all damages to any portion of the work occasioned by any of the above causes before its completion and acceptance and shall bear the expenses thereof.

7.7 NO PERSONAL LIABILITY - Neither the Director nor any other officer or authorized employee of the Department shall be personally responsible for any liability arising under the contract.

7.8 INSURANCE - Prior to commencing with the work, the Contractor shall, at its own expense, obtain and submit to the Department, Certificate of Insurance from an insurance company authorized by the laws of the State to issue such insurance in the State of Hawaii showing full policy coverage of the Contractor.

TYPES OF INSURANCE:

A. Workers' Compensation:

The Contractor shall obtain worker's compensation insurance for all persons whom they employ in carrying out the work under this contract. This insurance shall be in strict conformity with the requirements of the most current and applicable State of Hawaii Worker's Compensation Insurance laws in effect on the date of the execution of this contract and as modified during the duration of the contract. The minimum limit of liability for workers compensation is the HRS 386 statutory limit.

B. Comprehensive Automobile Liability:

The Contractor shall obtain Auto Liability Insurance covering all owned, non-owned and hired autos with a combined single Limit of not less than \$1,000,000 per accident for bodily injury and property damage with the State of Hawaii named as additional insured. The required limit of insurance may be provided by a single policy or with a combination of primary and excess policies.

C. Commercial General Liability:

The Contractor shall obtain General Liability insurance with a limit of not less than \$1,000,000 per occurrence and in the aggregates. The General liability insurance shall include the State of Hawaii as an additional insured. The required limit of insurance may be provided by a single policy or with a combination of primary and excess policies.

All policies must provide that 30 days prior written notice of cancellation or material change in coverage be given to certificate holders stated above.

Such insurance when accepted by the Director in writing shall become applicable and shall remain unmodified throughout the entire term of the contract and in no event shall be terminated or otherwise allowed to lapse prior to written certification of final acceptance of the work by the State. Such insurance aforementioned shall cover the State for all work performed under the contract, all work performed incidental thereto or directly or indirectly connected therewith, including other work performed outside of the work area, and all change orders.

Any delay in the submission and approval of insurance certificates shall not be justification of or grounds for a request by the Contractor postponing the issuance of a notice to proceed notwithstanding the fact that the Contractor shall not be allowed to proceed with the work until said certificates are submitted and approved.

Failure to obtain insurance in accordance with the Section, on the part of the Contractor, shall be considered a major breach of the contract; and should the State be forced to expend funds which would have been covered under the insurance, the Contractor agrees to assume the liability for such funds and to indemnify and hold the State harmless.

## SECTION 8 - PROSECUTION AND PROGRESS

8.1 PROGRESS OF WORK - The Contractor shall diligently prosecute the work to completion within the time limit specified in the proposal. The Contractor shall give its personal attention to the fulfillment of the contract and shall keep the work under its control. Work shall commence on the date indicated in the "Notice to Proceed" letter from the State.

8.2 LIQUIDATED DAMAGES - Time is of the essence in this contract and in case the Contractor fails to complete the work within the time specified in the proposal, damages will be sustained by the State. Since the amount of damages is difficult and not possible of definite ascertainment and proof, the amount of such damages are fixed in advance at the sum shown in the proposal for each and every calendar (or working) day which the Contractor has delayed in the completion of this contract; and the Contractor shall pay such amount as liquidated damages, and not by way of penalty, and in case the same are not paid, the State may deduct such amount thereof from any monies due or that may become due the Contractor under this contract.

If the Contractor finds it impossible for reasons beyond its control to complete the work within the contract time as specified, the Contractor shall, within 10 days from the first day of notification from the manufacturer or supplier of any delay and prior to the expiration of the contract time, make a written request to the Director for an extension of time setting forth therein the reasons which the Contractor believes will justify the granting of its request. The Contractor's plea that insufficient time was specified is not a valid reason for extension of time. If the Director finds that the work was delayed because of conditions beyond the control and without the fault of the Contractor, the Director may extend the time for completion in such extension as the conditions justify. The extended time for completion shall then be in full force and effect the same as though it were the original time for completion.

### 8.3 TEMPORARY SUSPENSION OF WORK

A. Order to stop work. The Director, may, by written order to the contractor, at any time, and without notice to any surety, require the contractor to stop all or any part of the work called for by this contract. This order shall be for a specified period not exceeding sixty (60) days after the order is delivered to the contractor, unless the parties agree to any further period. Any such order shall be identified specifically as a stop work order issued pursuant to this section. Upon receipt of such an order, the contractor shall forthwith comply with its terms and take all reasonable steps to minimize the occurrence of costs allocable to

the work covered by the order during the period of work stoppage. Before the stop work order expires, or within any further period to which the parties shall have agreed, the Director shall either:

1. Cancel the stop work order; or
2. Terminate the work covered by such order as provided in the "termination for default clause" or the "termination for convenience clause" of this contract.

B. Cancellation or expiration of the order. If a stop work order issued under this section is canceled or if the period of the order or any extension thereof expires, the contractor shall have the right to resume work. An appropriate adjustment shall be made in the delivery schedule or contract price, or both, and the contract shall be modified in writing accordingly; if:

1. The stop work order results in an increase in the time required for, or in the contractor's cost properly allocable to, the performance of any part of this contract; and
2. The contractor asserts a claim for such an adjustment within thirty (30) days after the end of the period of work stoppage; provided that, if the Director decides that the facts justify such action, any such claim asserted may be received and acted upon at any time prior to final payment under this contract.

C. Termination of stopped work. If a stop work order is not canceled and the work covered by such order is terminated for default or convenience, the reasonable costs resulting from the stop work order shall be allowable by adjustment or otherwise.

D. Adjustment of price. Any adjustment in contract price made pursuant to this clause shall be determined in accordance with the price adjustment clause of this contract.

#### 8.4 DEFAULT AND TERMINATION OF CONTRACT

A. Termination by Default. If the contractor refuses or fails to perform any of the provisions of this contract with such diligence as will ensure its completion within the time specified in this contract, or any extension thereof, otherwise fails to timely satisfy the contract provisions, or commits any other substantial breach of this contract, the Director may notify the contractor in writing of the delay or non-performance and if not cured in ten (10) days or any

longer time specified in writing by the Director, such officer may terminate the contractor's right to proceed with the contract or such part of the contract as to which there has been delay or a failure to properly perform. In the event of termination in whole or in part the Director may procure similar goods or services in the manner and upon terms deemed appropriate by the Director. The contractor shall continue performance of the contract to the extent it is not terminated and shall be liable for excess costs incurred in procuring similar goods or services.

1. Contractor's duties. Notwithstanding termination of the contract and subject to any directions from the Director, the contractor shall take timely, reasonable, and necessary action to protect and preserve property in the possession of the contractor in which the State or county has an interest.

2. Compensation. Payment for completed goods delivered and accepted by the State shall be at the contract price. Payment for the protection and preservation of property shall be in an amount agreed upon by the contractor and Director; if the parties fail to agree, the Director shall set an amount subject to the contractor's rights under chapter 3-126, HAR. The State may withhold from amounts due the contractor such sums as the Director deems to be necessary to protect the State against loss because of outstanding liens or claims of former lien holders and to reimburse the State for the excess costs incurred in procuring similar goods and services.

3. Excuse for nonperformance or delayed performance. Except with respect to defaults of subcontractors, the contractor shall not be in default by reason of any failure in performance of this contract in accordance with its terms, including any failure by the contractor to make progress in the prosecution of the work hereunder which endangers such performance, if the contractor has notified the Director within fifteen (15) days after the cause of the delay and the failure arises out of causes such as: acts of God; acts of the public enemy; acts of the State and any other governmental body in its sovereign or contractual capacity; fires; floods; epidemics; quarantine restrictions; strikes or other labor disputes; freight embargoes; or unusually severe weather. If the failure to perform is caused by the failure of a subcontractor to perform or to make progress, and if such failure arises out of causes similar to those set forth above, the contractor shall not be

deemed to be in default, unless the goods or services to be furnished by the subcontractor were unreasonably obtained from other sources in sufficient time to permit the contractor to meet the contract requirements. Upon request of the contractor, the Director shall ascertain the facts and extent of such failure, and if such officer determines that any failure to perform was occasioned by any one or more of the excusable causes, and that, but for the excusable cause, the contractor's progress and performance would have met the terms of the contract, the delivery schedule shall be revised accordingly, subject to the rights of the State under the clause entitled "Termination for Convenience". As used in this paragraph of this clause, the term "subcontractor" means subcontractor at any tier.

4. Erroneous termination for default. If, after notice of termination of the contractor's right to proceed under the provisions of this clause, it is determined for any reason that the contractor was not in default under the provisions of the clause, or that the delay was excusable under the provisions of paragraph (3), Excuse for nonperformance or delayed performance of this clause, the rights and obligations of the parties shall, if the contract contains a clause providing for termination for convenience of the State, be the same as if the notice of termination had been issued pursuant to such clause.

5. Additional rights and remedies. The rights and remedies provided in this clause are in addition to any other rights and remedies provided by law or under this contract.

B. Termination for convenience. The Director may, when the interests of the State so require, terminate this contract in whole or in part, for the convenience of the State. The Director shall give written notice of the termination to the contractor specifying the part of the contract terminated and when termination becomes effective.

1. Contractor's obligation. The contractor shall incur no further obligations in connection with the terminated work and on the dates set in the notice of termination the contractor will stop work to the extent specified. The contractor shall also terminate outstanding orders and subcontracts as they relate to the terminated work. The contractor shall settle the liabilities and claims arising out of the termination of subcontracts and orders connected with the terminated work. The Director

may direct the contractor to assign the contractor's right, title, and interest under terminated orders or subcontracts to the State. The contractor must still complete the work not terminated by the notice of termination and may incur obligations as are necessary to do so.

2. Right to goods. The Director may require the contractor to transfer title and deliver to the State in the manner and to the extent directed by the procurement officer:

- a. Any completed goods; and
- b. The partially completed goods and materials, parts, tools, dies, jigs, fixtures, plans, drawings, information, and contract rights hereinafter called "manufacturing material," as the contractor has specifically produced or specially acquired for the performance of the terminated part of this contract.

The contractor shall, upon direction of the Director, protect and preserve property in the possession of the contractor in which the State has an interest. If the Director does not exercise this right, the contractor shall use the contractor's best efforts to sell such goods and manufacturing materials. Use of this section in no way implies that the State has breached the contract by exercise of the termination for convenience clause.

3. Compensation:

a. The contractor shall submit a termination claim specifying the amounts due because of the termination for convenience together with cost or pricing data to the extent required by subchapter 15, chapter 3-122, HAR, bearing on such claim. If the contractor fails to file a termination claim within one (1) year from the effective date of termination, the Director may pay the contractor, if at all, an amount set in accordance with subparagraph c. below.

b. The Director and the contractor may agree to settlement provided the contractor has filed a termination claim supported by cost or pricing data to the extent required by subchapter 15, chapter 3-122, HAR, and that the settlement does not exceed the total contract price plus settlement costs reduced by payments previously made by the State, the

proceeds of any sales of goods and manufacturing materials under paragraph (2) of this clause, and the contract price of the work not terminated.

c. Absent complete agreement under subparagraph b above, the Director shall pay the contractor the following amounts, provided payments agreed to under subparagraph b. shall not duplicate payments under this subparagraph for the following:

(i) Contract prices for goods or services accepted under the contract;

(ii) Costs incurred in preparing to perform and performing the terminated portion of the work plus a fair and reasonable profit on such portion of the work, such profit shall not include anticipatory profit or consequential damages, less amounts paid or to be paid for accepted goods or services; provided that if it appears that the contractor would have sustained a loss if the entire contract would have been completed, no profit shall be allowed or included and the amount of compensation shall be reduced to reflect the anticipated rate of loss;

(iii) Costs of settling and paying claims arising out of the termination of subcontracts or orders pursuant to paragraph (1) of this clause. These costs must not include costs paid in accordance with subparagraph (ii) above.

(iv) The reasonable settlement costs of the contractor including accounting, legal, clerical, and other expenses reasonably necessary for the preparation of settlement claims and supporting data with respect to the terminated portion of the contract and for the termination of subcontracts thereunder, together with reasonable storage, transportation, and other costs incurred in connection with the protection or disposition of property allocable to the terminated portion of this contract. The total sum to be paid the contractor under this subparagraph shall not exceed the total contract price plus the reasonable settlement cost of the contractor reduced by the amount of

payments otherwise made, the proceeds of any sales of supplies and manufacturing materials under subparagraph b. of this paragraph, and the contract price of work not terminated.

d. Cost claimed, agreed to, or established under subparagraphs b. and c. shall be in accordance with chapter 3-123, H.A.R. bearing on such claim.

8.5 TERMINATION OF CONTRACTOR'S RESPONSIBILITY - The contract will be considered complete when all work has been completed, the work accepted by the Director, and the final estimate paid. The Contractor will then be released from further obligation except as set forth in the contract and bond, when applicable.

## SECTION 9 - PAYMENT

9.1 PAYMENT - The Contractor's bid price shall be inclusive of all costs, direct or indirect, including all taxes, required for the fulfillment of this contract.

Contract payments to the Contractor by the State shall be full payment, for furnishing all labor, and for furnishing and delivering all equipment, materials, supplies and other incidentals to the location(s) designated in these specifications.

9.2 PROGRESS PAYMENTS - If more than one shipment is required under these specifications, progress payments may be made to the Contractor after each shipment, provided the equipment materials, supplies, etc., furnished and delivered have satisfactorily met the requirements of these specifications. Five per cent (5%) of the amount of each progress payment shall be retained by the Department until the final acceptance of the work.

To expedite processing of all payments, for item(s) furnished and delivered to the Department, the Contractor shall forward an original and one copy of invoice with each shipment made to the recipient office.

Each invoice shall contain the following:

- A. Vendor's name, address and phone number.
- B. Contract or Purchase Order No.
- C. Description of item, the quantity, unit or lump sum price, sub-total and total.

9.3 FINAL ACCEPTANCE AND FINAL PAYMENT - Final acceptance means the acceptance in writing by the Director of the satisfactory completion of the work as provided under Section 8.5 followed by final payment in accordance with the Director's final estimate. The Department shall make final acceptance and payment promptly after the contract has been satisfactorily completed and final inspection made.

No payment will be made for any work which was not authorized by the Director in writing.

Final payment shall be made only after the issuance of the notice of final acceptance and after the Contractor has filed with the Director the following:

- A. Consent of the Contractor's surety, when applicable, of the final payment;

B. Satisfactory evidence by affidavit that all debts resulting from the contract have been fully paid or satisfactorily secured;

C. A current "Certificate of Vendor Compliance" issued by the Hawaii Compliance Express (HCE). The Certificate of Vendor Compliance is used to certify the Contractor's compliance with (a) Section 103D-328, HRS (for all contracts \$25,000 or more) which requires a current tax clearance certificate issued by the Hawaii State Department of Taxation and the Internal Revenue Service; (b) Chapters 383, 386, 392, and 393, HRS; and (c) Subsection 103D-310(c), HRS. The State reserves the right to verify that compliance is current prior to the issuance of final payment. Contractors are advised that non-compliance status will result in final payment being withheld until compliance is attained.

The filing of willfully false affidavits will disqualify the Contractor from bidding on future work of the Department.

SECTION 10 – FURNISHING AND DELIVERING METAL GUARDRAILS, POSTS,  
ELEMENT, END TREATMENT SYSTEMS, HARDWARE AND IMPACT ATTENUATORS

**10.1 DESCRIPTION OF WORK**

This work shall consist of furnishing and delivering metal guardrails, posts, element, end treatment systems, hardware and impact attenuators, on an “as-needed” basis during the Contract period for the islands of Oahu and Maui; and delivered to the place designated herein, all in accordance with the requirements of these Specifications, the Standard Specifications and the Standard Plans.

**10.2 GENERAL**

(A) Material.

1. Materials shall conform to the Standard Specifications and the Standard Plans, and the QUADGUARD brand or its approved equal, as applicable.

<b>BID ITEM NO.</b>	<b>Material</b>	<b>Reference</b>
1 to 21	Guardrail Material (Metal guardrails, posts, element, end treatment systems and hardware).	Standard Specification Section 710, Standard Plan TE-57, TE-57A; Sheets M-5A, B-5B, M-2 & M-4; Detail RWT02 (on page B-5B).
22, 23	Inertial Barrier Systems (“Sand Barrels”).	In accordance with Section 10.2.A.1 below.
24	Terminal Impact Attenuators – Permanent Plastic Nose Assembly.	Standard Specification Section 693.
25	Terminal Impact Attenuators – Plastic Nose Assembly.	Standard Specification Section 693.
26	Terminal Impact Attenuators – Diaphragm Assembly.	Standard Specification Section 693.

27	Terminal Impact Attenuators – Diaphragm Assembly.	Standard Specification Section 693.
28	Terminal Impact Attenuators – Diaphragm Assembly.	Standard Specification Section 693.
29	Terminal Impact Attenuators – Diaphragm Assembly.	Standard Specification Section 693.
30	Terminal Impact Attenuators – Diaphragm Assembly.	Standard Specification Section 693.
31	Terminal Impact Attenuators – Diaphragm Assembly.	Standard Specification Section 693.
32	Terminal Impact Attenuators – Diaphragm Assembly.	Standard Specification Section 693.
33	Terminal Impact Attenuators – Diaphragm Assembly.	Standard Specification Section 693.
34	Terminal Impact Attenuators – Cartridge Assembly	Standard Specification Section 693.

- a. The Inertial Barrier System (“Sand Barrels”) shall consist of the following:
- i. Container – The Inertial Barrier shall consist of modules 200, 400, 700, 1400, and 2100 lbs. sizes. Modules in 200, 400, and 700 lbs. may consist of a container molded in one (1) or two (2) pieces. The material shall be durable, weatherproof, and formulated to resist deterioration from ultraviolet rays. The color shall be yellow. The 1400 and 2100 lbs. model must be of continuous molded construction and be nestable. The modules shall be designed and manufactured from frangible polyethylene material, which shall shatter upon impact to permit dispersion of the sand mass container within.
  - ii. Lid – Each module shall have a black lid, which locks securely over the top lip of the outer container. Material shall be durable, weatherproof, and shall be formulated to resist deterioration from ultraviolet rays.
  - iii. Insert – Modules in 200, 400 and 700 lbs. may or may not require a cone-shaped supporting insert used to support various sand masses. Cone inserts, if supplied, shall be one-piece molded construction and be nestable.
  - iv. Sand – Sand placed into these modules should be washed concrete sand conforming to ASTM-C-33 or equal and as specified by the Manufacturer’s requirements.

Each Inertial Barrier System array shall be configured to provide a satisfactory average rate of deceleration (8 g’s maximum preferred for each row) for errant vehicles in the weight ranges of 1810 and 4410 lbs. The inertial barrier system shall meet the requirements of Manual for Assessing Safety Hardware (MASH) 350 for the appropriate Test Level (TL-2 for Low Speed Design Roadways and TL-3 for High Speed Design Roadways) and for non-redirective gating crash cushions. For impact vehicles weighing between 1810 and 4410 lbs. and traveling at speeds of up to 62 mph for TL-3 (44 mph for TL-2), the maximum 24-inch occupant fail space velocity shall be less than 39 ft/sec and the vehicle’s highest 10, millisecond occupants ride-down acceleration shall be less than 20 g’s.

The center of gravity of each properly filled module shall be at a height which will aid in controlling the pitch of standard passenger vehicles.

- b. Terminal impact attenuator shall be redirect, non-gating, and energy absorbing and be in accordance with the 2016 edition of the American Association of

### **10.3 MINIMUM QUANTITY OF STORED MATERIALS**

- (A) Due to limited spaces in storage facilities in State baseyards, the Contractor shall store/stock a **minimum quantity/inventory of ten (10%) percent** of the estimated yearly quantity of each bid item in the Proposal Schedule in the Contractor's local storage facility. The stored items shall be readily available for furnishing and delivering to the State upon request and upon the issuance of a Purchase Order. The Contractor shall maintain the above-mentioned minimum quantity/inventory of stored/stocked materials by continued replenishment. Storing shall be incidental to the cost of furnishing and delivering the specified materials.
- (B) The State reserves the right to request the Contractor to furnish and deliver all estimated yearly quantity of each bid item in the Proposal Schedule upon the issuance of the Notice to Proceed or anytime during the term of the contract. When the State's order of materials exceeds the quantity of materials that is available in the Contractor's inventory in the local storage facility, the Contractor shall have a maximum of one hundred twenty (120) calendar days to deliver the remaining quantity.
- (C) At the end of each term but prior to the expiration of the Contract, the State shall issue a Purchase Order to procure all remaining stored materials. These remaining stored materials should be the difference of the total estimated yearly quantity of each bid item in the Proposal Schedule and what has been furnished and delivered to the respective district.
- (D) To prolong the life of the specified materials, the Contractor shall protect the materials from the degradation effects of the weather and other elements or as prescribed by the manufacturer.

### **10.4 MINIMUM ORDER PER YEAR**

The State shall place a **minimum** order of materials per year, at a minimum dollar amount of thirty (30%) percent of the respective District's total estimated maximum yearly contract cost in the Proposal Schedule

### **10.5 DELIVERY**

- (A) Description.

"DELIVERY" shall mean transporting of the specified materials to the respective addresses below and unloading and stacking, as applicable, to a location as directed by the recipient State. The Contractor shall transport, unload and stack the specified material utilizing his or her own equipment and personnel or his or her subcontractor's equipment and personnel. Cost of "delivery" as defined above shall be incidental to the cost of furnishing and delivering the specified materials.

(B) Coordination and Location of Deliver.

All deliveries under this contract shall be coordinated with the State or a duly authorized representative. Location of delivery and contact information is as follows:

<p><b>District Engineer – Oahu District</b> Highways Division – State DOT <b>Kakoi Baseyard</b> 727 Kakoi Street Honolulu, Hawaii 96819 <b>or</b> <b>Pearl City Baseyard</b> 820 2<sup>nd</sup> Street Pearl City, Hawaii 96782 <b>Point of Contact:</b> Mr. Michael Coleman (Structures Subunit Supervisor – Oahu Dist.) Phone No.: (808) 831-6797 Email: mark.t.anama@hawaii.gov</p>	<p><b>District Engineer – Maui District</b> Highways Division – State DOT <b>Kahului Baseyard</b> 650 Palapala Drive Kahului, Hawaii 96732 <b>Point of Contact:</b> Ms. Annette Matsuda (District Engineer – Maui District) Phone No.: (808) 873-3535 Email: annette.dh.matsuda@hawaii.gov</p>
--	--

(C) Packaging and Marking.

The material shall be packaged in convenient size, clean manufactured containers and marked for shipment in accordance with the respective address as specified in Section 10.5.B Coordination and Location of Delivery, in the quantities indicated in the Purchase Order or Proposal, as applicable. All cases shall be labeled to allow quick identification of the contents. Labeling shall contain the following information:

- |                            |                           |
|----------------------------|---------------------------|
| 1. Material description    | 7. Contractor's address   |
| 2. Size                    | 8. Manufacturer's name    |
| 3. Count                   | 9. Manufacturer's address |
| 4. Trademark or trade name | 10. Contract number       |
| 5. Date of manufacture     | 11. Project number        |
| 6. Contractor's name       |                           |

The bid price shall include the cost of containers, which shall become the property of the Department. The Contractor shall replace any highway pavement marker and/or adhesive material which have become unfit for use.

(D) Delivery Period and Capability.

1. Sustained Delivery Capability.
  - a. Upon the request of materials and upon the issuance of Purchase Order from the State, the Contractor shall have a maximum of fourteen (14) calendar days to furnish and deliver any materials that is in storage at the Contractor's local storage facility.

- b. When the State’s order of materials exceeds the quantity of materials that is available in the Contractor’s inventory in the local storage facility, the Contractor shall have a maximum of one hundred twenty (120) calendar days to deliver the remaining quantity.
- c. The Contractor shall maintain this sustained delivery capability through continued replenishment of inventory throughout the term of the contract.
- d. Refer to Section 8.2 Liquidated Damages for the amount that shall be assessed from the Contractor for failure to deliver in accordance with this Section.

(E) Notification of Delivery.

The Contractor shall have the shipper notify the recipient district by calling or emailing the point of contact as listed in Section 10.5.B Coordination and Location of Delivery of this section at least five (5) working days in advance as to the day and time of delivery. The day and time of delivery shall be subject to approval of the State.

(F) Inspection of Material.

The Contractor and the State shall make a visual and physical check of the materials delivered for damage, shortages, etc. Payment will not be processed until the Contractor and State have both concluded that the materials delivered meet the contract requirements.

**10.6 BIDDER/CONTRACTOR SUBMITTAL**

For each of the material described and in accordance with the schedule as specified in Section 10.6.G Schedule of Submitting Required Documents of this section, the Contractor shall submit the following as original documents to:

Construction and Maintenance Branch, Room 404  
 Department of Transportation – Highways Division  
 869 Punchbowl Street  
 Honolulu, Hawaii 96813

**(A) Material Certificate of Compliance for Guardrail materials** (metal guardrails, posts, element, end treatment systems and hardware).

- 1. The Contractor shall certify that the materials delivered conform to the requirements of the Standard Specifications, the Standard Plans, and these Specifications. The certificate shall be notarized by the manufacturer.
  - a. The notarized certificate shall include, as a minimum, the following data:
    - i. Name of manufacturer

- ii. Material being certified
- iii. Batch or lot number
- iv. Applicable test results of finished products
- v. Applicable specifications
- vi. Date
- vii. Statement of compliance by a responsible official (employee) of the Manufacturer or by his representative. The Manufacturer's statement of compliance shall be notarized.
- viii. Project identification

**(B) Material Certificate of Compliance for Terminal Impact Attenuator.**

1. The Contractor shall certify that the materials delivered conform to the requirements of the Standard Specifications, the Standard Plans, and these Specifications. The certificate shall be notarized by the manufacturer.
  - a. The notarized certificate shall include, as a minimum, the following data:
    - i. Name of manufacturer
    - ii. Material being certified
    - iii. Batch or lot number
    - iv. Applicable test results of finished products
    - v. Applicable specifications
    - vi. Date
    - vii. Statement of compliance by a responsible official (employee) of the Manufacturer or by his representative. The Manufacturer's statement of compliance shall be notarized.
    - viii. Project identification
2. In addition, the Contractor shall submit the following:
  - a. The Federal Highway Administration (FHWA) approval letter certifying that the Inertial Barrier Systems to be furnished and delivered under this contract is in compliance with the AASHTO Manual for Assessing Safety Hardware (MASH) for the appropriate Test Level (TL-2 for Low Speed Design Roadways and TL-3 for High Speed Design Roadways).
  - b. The Contractor's self-certified MASH compliant letter.

**(C) Material Certificate of Compliance for Inertial Barrier Systems.**

1. The Contractor shall certify that the materials delivered conform to the requirements of the Standard Specifications, the Standard Plans, and these Specifications. The certificate shall be notarized by the manufacturer.
  - a. The notarized certificate shall include, as a minimum, the following data:

- i. Name of manufacturer
- ii. Material being certified
- iii. Batch or lot number
- iv. Applicable test results of finished products
- v. Applicable specifications
- vi. Date
- vii. Statement of compliance by a responsible official (employee) of the Manufacturer or by his representative. The Manufacturer's statement of compliance shall be notarized.
- viii. Project identification

2. In addition, the Contractor shall submit the following:

- a. The Federal Highway Administration (FHWA) approval letter certifying that the Inertial Barrier Systems to be furnished and delivered under this contract is in compliance with the AASHTO Manual for Assessing Safety Hardware (MASH) for the appropriate Test Level (TL-2 for Low Speed Design Roadways and TL-3 for High Speed Design Roadways).
- b. The Contractor's self-certified MASH compliant letter.

**(D) Notarized Letter of Certification** stating that materials which shall be supplied in this contract shall be compliance with the Standard Specifications, the Standard Plans and these Specifications. The notarized letter of certification shall be received the Project Manager no later than seven (7) working days from the date of receipt o the written request from the State. Failure to submit may result in bid rejection.

**(E) Installation and Maintenance System Manual for Terminal Impact Attenuator.**

Submit three (3) copies of the manufacturer's manual.

**(F) Installation and Maintenance Training.**

Upon request by the State, the Contractor, through the manufacturer, shall provide installation/application and maintenance training to each recipient District's personnel. Cost of training (i.e., materials, equipment and expertise used during the training, etc.) shall be incidental to furnishing and delivering materials that are required of this contract.

**(G) Schedule of Submitting Required Documents.**

1. Prior to award: The Contractor shall submit the Letter of Intent (notarized) and Installation and Maintenance System Manual for Terminal Impact Attenuator as specified Sections 10.6.D and E and they shall be received by the Project Manager no later than seven (7) working days from the date of receipt of the written request from the State.

Failure by the bidder to submit: The bidder may be considered non-compliant with the requirements of the Specifications if the bidder fails to submit the specified documents no later than seven (7) working days from the date of receipt of the written request from the State. This failure may result in bid rejection.

2. When there are changes to the composition or manufacturing process of any material as specified in this contract: Throughout the life of the contract including any contract extension(s), report any changes, in writing, in the composition or manufacturing process of any material as specified in this contract to Construction and Maintenance Branch at the address as specified in this section. Any changes require a resubmission of Material Certificate of Compliance.
3. Upon each order of materials by the State, the Contractor shall require the manufacturer to furnish a material Certificate of Compliance. The Contractor shall furnish the certificate to the Construction and Maintenance Branch as indicated in Section 10.6 Bidder/Contractor Submittal, upon delivery of the required material. The Contractor shall certify the manufacturer's statement of compliance as specified in Section 10.6.A.1.a.vii.
  - a. The materials in the Certificate of Compliance may be reviewed by the Materials Testing Branch for acceptance. The review process shall be completed within five (5) to ten (10) working days from the time of receipt of the document(s). The Construction and Maintenance Branch will notify the Contractor and the recipient District of the result.

**10.7 TERM OF CONTRACT:** The term of this contract shall be for twelve (12) months from the date indicated on the Notice to Proceed from the State unless renewed as provided for in Section 10.8 Option to Extend Term, herein below.

**10.8 OPTION TO EXTEND TERM:** Subject to the availability of State funds, this contract may be extended up to four (4) additional twelve (12) month periods, or portions thereof, without the necessity for re-bidding upon mutual agreement between the State and the Contractor in writing provided the contract price for the extended period shall remain equal to or less than the initial bid price; with adjustments as provided in Section 10.9 Escalation Clause. The entire term of contract, including extensions, shall not exceed sixty (60) months.

**10.9 ESCALATION CLAUSE:** At the beginning of each twelve (12) month period, the cost of all bid items will be automatically increased by the percent change of the annual U.S. City Average, Consumer Price Index for All Urban Consumers (CPI-U) from the previous calendar year (percent change from the previous December). Information on the CPI-U can be found online at <https://www.bls.gov/cpi>. Increases shall be capped at 5% per twelve (12) month period. Price adjustments shall be made only at the time of extension of the contract.

## **10.10 MEASUREMENT AND PAYMENT**

- (A) Specified metal guardrails, posts, element, end treatment systems, hardware and impact attenuators will be paid for at the contract price per unit, which respective price will be full compensation for all materials, labor, equipment, applicable taxes and incidentals necessary to manufacture and fabricate the specified items, all in accordance with these specifications to furnish and deliver the specified items to the places designated in Section 10.5.B Coordination and Location of Delivery.

Incidental costs include, but not limited to the following:

Item	Reference
Storage of materials	Section 10.3.A
Cost of delivery (transporting, unloading and stacking)	Section 10.5.A
Insurance	Section 7.8 Insurance

- (B) Payments for purchases made will be made by Purchase Order as specified in Section 4.6 Contract To Be Indefinite Quantity. *Refer to Section 9.2 Progress Payments, of the Special Provisions, for additional information on Purchase Orders and processing invoices.*

STATE OF HAWAII  
DEPARTMENT OF TRANSPORTATION  
HIGHWAYS DIVISION  
HONOLULU, HAWAII

APPENDICES

Contents:

- Appendix A Standard Plan, TE-57, TE-57A; Sheets M-5A, B-5B, M-2 & M-4
- Appendix B Sample – Monthly Invoice
- Appendix C Sample – Satisfactory Evidence by Affidavit for Final Payment







# Appendix A (continuation)

FED. ROAD DIST. NO.	STATE	PROJ. NO.	FISCAL YEAR	SHEET NO.	TOTAL SHEETS
HAWAII	HAW.				

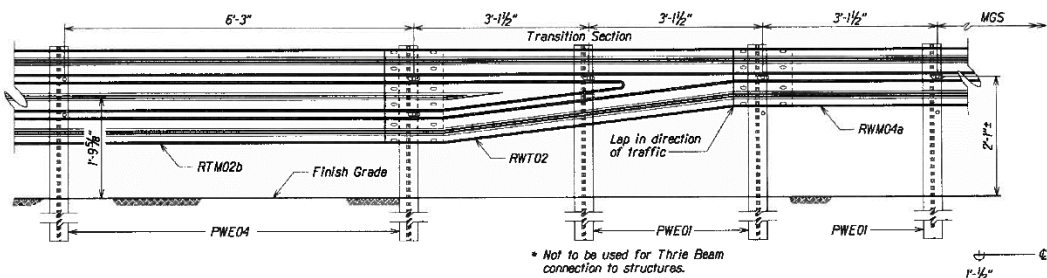

\* Not to be used for Thrie Beam connection to structures.

### TRANSITION SECTION\*

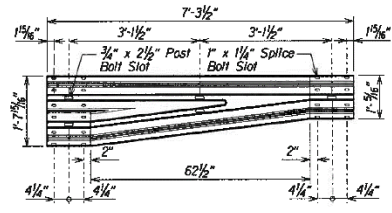

TRANSITION SECTION (RWT02)

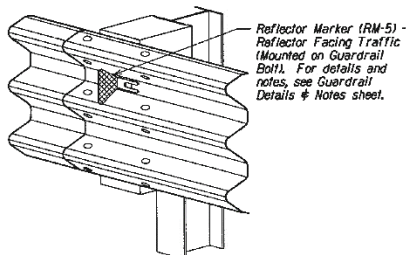

### TYPICAL INSTALLATION OF REFLECTOR MARKER (RM-5)

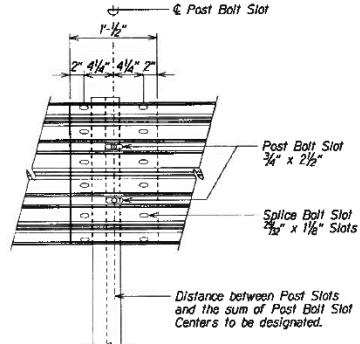

### RAIL SPLICE

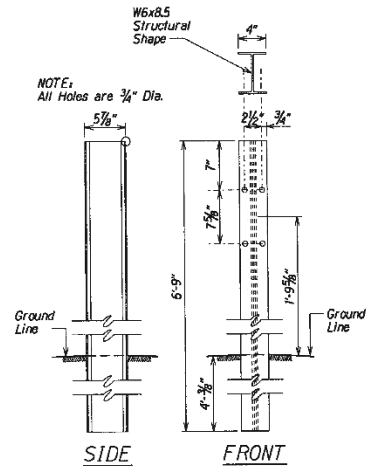

### THRIE-BEAM STRONG POST FOR PLASTIC SPACER BLOCKS PWE04

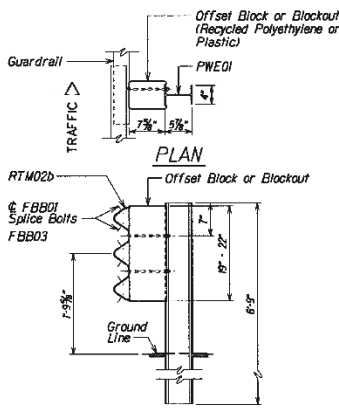

ELEVATION STRONG POST THRIE-BEAM GUARDRAIL (SGR09a)

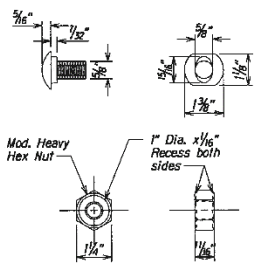

DESIGNATOR	L
FBB01	1 3/8"
FBB02	2"
FBB03	10"

GUARDRAIL BOLTS AND RECESSED NUT

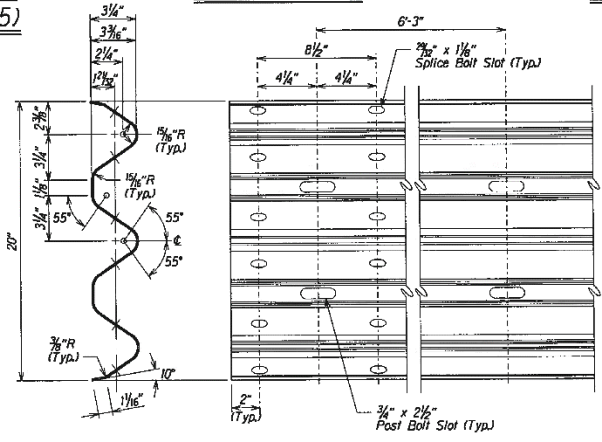

1 & 2 SPACE THRIE-BEAM GUARDRAIL (RTM02b)



REDUCED PLAN (HALF SIZE)  
0 1 2 3  
3 INCHES OF ORIGINAL PLAN

STATE OF HAWAII  
DEPARTMENT OF TRANSPORTATION  
HIGHWAYS DIVISION  
**STRONG POST THRIE-BEAM GUARDRAIL**

Scale: NTS Date: XX, 199X  
SHEET No. 1 OF 1 SHEETS

PREPARED BY: [ ]  
 CHECKED BY: [ ]  
 DESIGNED BY: [ ]  
 DRAWN BY: [ ]  
 DATE: [ ]



# Appendix A (continuation)

FED. ROAD DIST. NO.	STATE	PROJ. NO.	FISCAL YEAR	SHEET NO.	TOTAL SHEETS
HAWAII	HAW.				

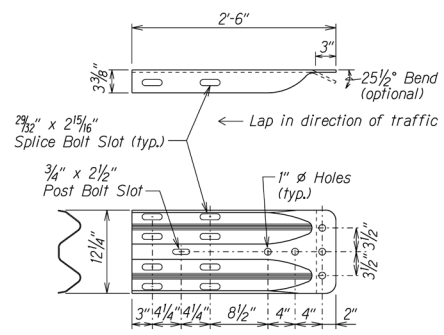

DESIGNATOR	BASE METAL THICKNESS
RWE02b	10 Gauge

**W-BEAM TERMINAL CONNECTOR (RWE02b)**

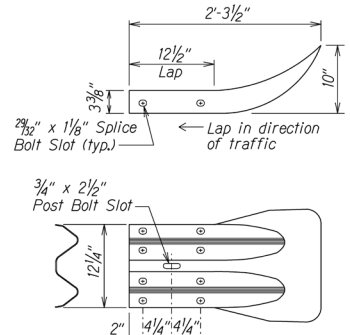

DESIGNATOR	BASE METAL THICKNESS
RWE01a	12 Gauge

**W-BEAM END SECTION (FLARED RWE01a)**

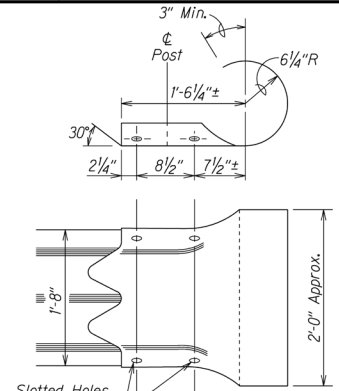

DESIGNATOR	BASE METAL THICKNESS
RTE02b	10 Gauge

**THRIE-BEAM SECTION (ROUNDED) (RTE02b)**

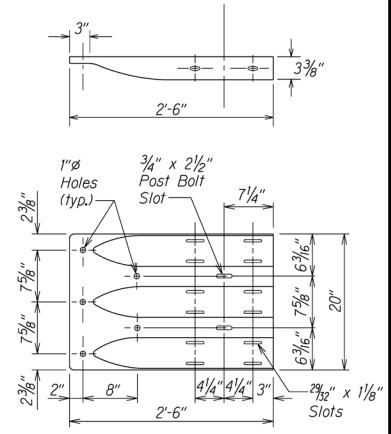

DESIGNATOR	BASE METAL THICKNESS
RTE01b	10 Gauge

**THRIE-BEAM TERMINAL CONNECTOR (RTE01b)**

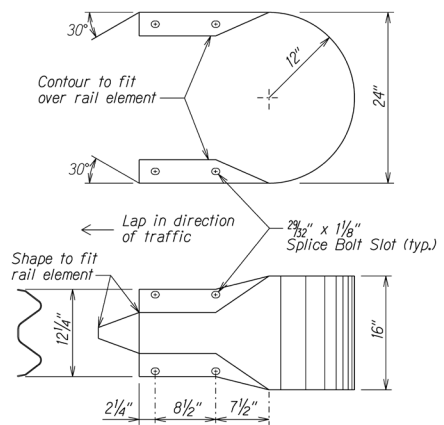

DESIGNATOR	BASE METAL THICKNESS
RWE06a	12 Gauge

**W-BEAM END SECTION (BUFFER RWE06a)**

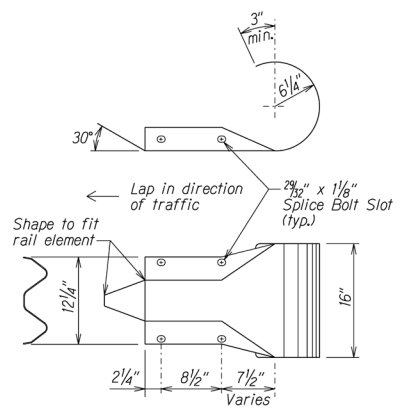

DESIGNATOR	BASE METAL THICKNESS
RWE03a	12 Gauge

**W-BEAM END SECTION (ROUNDED RWE03a)**

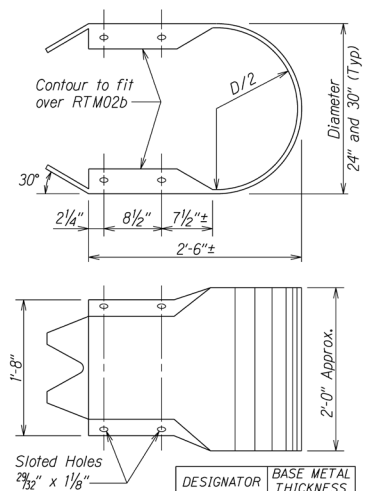

DESIGNATOR	BASE METAL THICKNESS
RTE03b # RTE04b	10 Gauge

**THRIE-BEAM END SECTION (BUFFER RTE03b or RTE04b)**



STATE OF HAWAII  
DEPARTMENT OF TRANSPORTATION  
HIGHWAYS DIVISION

**GUARDRAIL TERMINAL CONNECTORS  
AND END SECTIONS**

Scale: NTS Date: XX, 20XX

SHEET No. x OF x SHEETS

**Appendix B**

**Sample – Monthly Invoice**

**Guard Rail Materials Supply Co.**

1234 Any Street, Honolulu, Hawaii 12345 Phone (808) 123-1234 Fax (808)-123-1234 Email: name@email.com

Bill To: District Engineer – Oahu District  
Highways Division  
Department of Transportation  
727 Kakoi Street  
Honolulu, Hawaii 96819

Date: \_\_\_\_\_  
Invoice No.: \_\_\_\_\_  
Contract No.: \_\_\_\_\_  
Purchase Order No.: \_\_\_\_\_  
Project No.: **HWY-C-03-23**

Project Title: Furnishing and Delivering Metal Guardrails, Posts, Element, End Treatment Systems, Hardware and Impact Attenuators, Islands of Oahu and Maui

Periods Covered: **January 17, 2023 to February 16, 2023** (full pay period, head-to-tail format, first pay period from the NTP date to following month similar to this sample)

<b>Bid Item No.</b>	<b>Description</b>	<b>Qty</b>	<b>Unit</b>	<b>Unit Price</b>	<b>Amount</b>
1	Metal W-Beam Single Galvanized Guardrail, 12 ga x 12'-6", with intermediate holes 6'-3" o.c.	2,127	Each	\$ _____	\$ _____
2	Metal Thrie Beam Galvanized Guardrail 12 ga x 12'-6", with intermediate holes at 6'-3" o.c.	30	Each	\$ _____	\$ _____
29	Guardrail Galvanized Back-up Plates	1,587	Each	\$ _____	\$ _____
33	5/8"x10" Galvanized Guardrail Bolt, Button Head with Recess Nut	8,000	Each	\$ _____	\$ _____
Subtotal					\$ _____
Less Deductions					\$ _____
Subtotal					\$ _____
Less 5% retainage from payment per Section 9.2 Progress Payments, of the Special Provisions and the Specifications.					\$ _____
<b>Total Amount Due</b>					\$ _____

I certify that services requested under the contract have been performed by Elevator Maintenance Services in accordance with the contract.

\_\_\_\_\_  
Signature  
First J. Name  
President  
Guard Rail Materials Supply Co.

**Appendix C**  
**Sample – Satisfactory Evidence by Affidavit for Final Payment**

**Guard Rail Materials Supply Co.**

1234 Any Street, Honolulu, Hawaii 12345    Phone: (808) 123-1235    Email: name@email.com

Date:

State of Hawaii  
Department of Transportation  
869 Punchbowl Street  
Honolulu, Hawaii 96813-5097

Dear Sir/Madam:

Pursuant to Section 9.3 Final Payment, of the Specifications, I hereby certify that all debts resulting from Contract No. \_\_\_\_\_, Project No. HWY-C-03-17, Project Title: Furnishing and Delivering Metal Guardrails, Posts, Element, End Treatment Systems, Hardware and Impact Attenuators, Islands of Oahu and Maui, have been fully paid or satisfactorily secured.

Cordially,

\_\_\_\_\_  
First J. Name  
President  
Guard Rail Materials Co.

Subscribed and sworn to me  
This \_\_\_\_\_ day of \_\_\_\_\_, 20\_\_

\_\_\_\_\_  
Notary Public, First Judicial Circuit,  
State of Hawaii

My Commission Expires: \_\_\_\_\_



The bidder shall refer to Section 10.6(G) Schedule of Submitting Required Documents and be familiar with the requirements prior to submitting their bids. The bidder, **starting with the lowest bidder**, is required to submit specific documents.

**Failure by the bidder to submit.** The bidder may be considered non-compliant with the requirements of the Special Provisions and the Specifications if the bidder fails to submit the documents to the Project Manager no later than **seven (7) working days** from the date of receipt of the written request from the State. This failure may result in bid rejection by the Department of Transportation.

STATE OF HAWAII  
DEPARTMENT OF TRANSPORTATION  
HIGHWAYS DIVISION  
HONOLULU, HAWAII

PROPOSAL

PROPOSAL TO THE STATE OF HAWAII  
DEPARTMENT OF TRANSPORTATION  
HIGHWAYS DIVISION

PROJECT: FURNISHING AND DELIVERING METAL  
GUARDRAILS, POSTS, ELEMENT, END TREATMENT  
SYSTEMS, HARDWARE AND IMPACT  
ATTENUATORS, ISLANDS OF OAHU AND MAUI

PROJECT NO.: HWY-C-03-23

CONTRACT TIME: Twelve (12) months from date indicated in the Notice to  
Proceed from the Department with options to extend as  
provided for in Section 10.8 of the Specifications.

LIQUIDATED DAMAGES: Refer to Section 8.2 Liquidated Damage, of the Special  
Provisions.

NOTE: BID, PERFORMANCE AND PAYMENT BONDS ARE  
NOT REQUIRED FOR THIS PROJECT.

Director of Transportation  
AliiAIMoku Hale  
869 Punchbowl Street  
Honolulu, Hawaii 96813

Dear Sir:

The undersigned bidder declares the following:

1. It has not, either directly or indirectly, entered into any agreement, participated in any collusion, or otherwise taken any action in restraint of free competitive bidding in connection with this proposal.
2. It has not been assisted or represented on this matter by any individual who has, in a State capacity, been involved in the subject matter of this contract within the past two years.
3. It has not and will not, either directly or indirectly offered or given a gratuity (i.e. an entertainment or gift) to any State or County employee to obtain a contract or favorable treatment under a contract.

The undersigned bidder further agrees to the following:

1. If this proposal is accepted, it shall execute a contract with the Department to provide all necessary labor, machinery, tools, equipment, apparatus and any other means of construction, to do all the work and to furnish all the materials specified in the contract in the manner and within the time therein prescribed in the contract, and that it shall accept in full payment therefore the sum of the unit and/or lump sum prices as set forth in the attached proposal schedule for the actual quantities of work performed and materials furnished and furnish satisfactory security in accordance with Section 103D-324, Hawaii Revised Statutes, within 10 days after the award of the contract or within such time as the Director of Transportation may allow after the undersigned has received the contract documents for execution, and is fully aware that non-compliance with the aforementioned terms will result in the forfeiture of the full amount of the bid guarantee required under Section 103D-323, Hawaii Revised Statutes.

Matls. & Serv.  
r12/2020

2. That the quantities given in the attached proposal schedule are approximate only and are intended principally to serve as a guide in determining and comparing the bids.
3. That the Department does not either expressly or by implication, agree that the actual amount of work will correspond therewith, but reserves the right to increase or decrease the amount of any class or portion of the work, or to omit portions of the work, as may be deemed necessary or advisable by the Director of Transportation, and that all increased or decreased quantities of work shall be performed at the unit prices set forth in the attached proposal schedule except as provided for in the specifications.
4. In case of a discrepancy between unit prices and the totals in said Proposal Schedule, the unit prices shall prevail.
5. Agrees to begin work within 10 working days after the date of notification to commence with the work, which date is in the notice to proceed, and shall finish the entire project within the time prescribed.
6. The Director of Transportation reserves the right to reject any or all bids and to waive any defects when in the Director's opinion such rejections or waiver will be for the best interest of the public.

Receipt is hereby acknowledged and complete examination is hereby expressly guaranteed of the following listed items: the specifications, the notice to bidders, the special provisions, if any, the proposal, the plans, if any, and the contract form.

The undersigned acknowledges receipt of any addendum, issued by recording in the space below the date of receipt.

Addendum No. 1 \_\_\_\_\_ Addendum No. 3 \_\_\_\_\_  
Addendum No. 2 \_\_\_\_\_ Addendum No. 4 \_\_\_\_\_

The undersigned hereby certifies that the bid prices contained in the attached proposal schedule have been carefully checked and are submitted as correct, final and are net prices.

\_\_\_\_\_  
Bidder (Company Name)

By \_\_\_\_\_  
Authorized Signature

\_\_\_\_\_  
Print Name and Title

\_\_\_\_\_  
Business Address

\_\_\_\_\_  
Business Telephone      Email

\_\_\_\_\_  
Date

\_\_\_\_\_  
Contact Person (If different from above)

Phone: \_\_\_\_\_ Email: \_\_\_\_\_

\*Hawaii General Excise Tax License No. \_\_\_\_\_

NOTE:

If bidder is a CORPORATION, the legal name of the corporation shall be set forth above, the corporate seal affixed, together with the signature(s) of the officer(s) authorized to sign contracts on behalf of the corporation. Please attach to this page current (not more than six months old) evidence of the authority of the officer(s) to sign on behalf of the corporation.

If bidder is a PARTNERSHIP, the true name of the partnership shall be set forth above with the signature(s) of the general partner(s) authorized to sign contracts on behalf of the partnership. Please attach to this page current (not more than six months old) evidence of the authority of the partner(s) to sign on behalf of the partnership.

If bidder is an INDIVIDUAL, the bidder's signature shall be placed in the space provided therefore on page PF-4.

If signature is by an agent, other than an officer of a corporation or a partner of a partnership, a POWER OF ATTORNEY must be on file with the Department prior to the opening of bids or submitted with the bid; otherwise, the bid may be rejected as irregular and unauthorized.

\*Bidder will be considered an out-of-state vendor if Hawaii General Excise Tax License No. is not indicated. See Section 2.8 Out-of-State Bidders of the Specifications.

FURNISHING AND DELIVERING METAL GUARDRAILS, POSTS, ELEMENT,  
 END TREATMENT SYSTEMS, HARDWARE AND IMPACT ATTENUATORS  
 PROJECT NO. HWY-C-03-23  
 ISLANDS OF OAHU AND MAUI  
**PROPOSAL SCHEDULE**

**1. METAL GUARDRAIL AND POST**

BID ITEM NO.	ITEM	BRAND/ITEM NO.	OAHU DISTRICT			MAUI DISTRICT		
			EST. YEARLY QTY. (EACH) (A)	UNIT PRICE (B)	AMOUNT (A x B)	EST. YEARLY QTY. (EACH) (C)	UNIT PRICE (D)	AMOUNT (C x D)
1	METAL THRIE BEAM GALVANIZED GUARDRAIL 12 GA x 12'-6", WITH INTERMEDIATE HOLES AT 6'-3" O.C. (Refer to Standard Plan TE-57 & TE-57A, as applicable, Appendix A of the Appendices)	_____	30	\$ _____	\$ _____	0	\$ 00.00	\$ 00.00
2	METAL THRIE BEAM GALVANIZED GUARDRAIL SPACER BLOCK, 12 GA. (Refer to Standard Plan TE-57A, Appendix A of the Appendices or Detail PWB03, Sheet M-5A, of the Appendices)	_____	75	\$ _____	\$ _____	0	\$ 00.00	\$ 00.00
3	METAL GALVANIZED W-BEAM END SECTION, ROUNDED ¾ WRAP TERMINAL (RD) 12 GA. (Refer to Detail RWE03a, Sheet M-4, Appendix A of the Appendices)	_____	180	\$ _____	\$ _____	0	\$ 00.00	\$ 00.00
4	METAL THRIE BEAM TO W-BEAM TRANSITION SECTION GALVANIZED (Refer to Detail RWT01b, Sheet M-5A, Appendix A of the Appendices)	_____	30	\$ _____	\$ _____	0	\$ 00.00	\$ 00.00

FURNISHING AND DELIVERING METAL GUARDRAILS, POSTS, ELEMENT,  
 END TREATMENT SYSTEMS, HARDWARE AND IMPACT ATTENUATORS  
 PROJECT NO. HWY-C-03-23  
 ISLANDS OF OAHU AND MAUI  
**PROPOSAL SCHEDULE**

**1. (continuation) METAL GUARDRAIL AND POST**

BID ITEM NO.	ITEM	BRAND/ITEM NO.	OAHU DISTRICT			MAUI DISTRICT		
			EST. YEARLY QTY. (EACH) (A)	UNIT PRICE (B)	AMOUNT (A x B)	EST. YEARLY QTY. (EACH) (C)	UNIT PRICE (D)	AMOUNT (C x D)
5	METAL THRIE BEAM TO W-BEAM TRANSITION SECTION GALVANIZED <i>(Refer to Detail RWT02, Sheet B-5B, Appendix A of the Appendices)</i>	_____	30	\$ _____	\$ _____	0	\$ 00.00	\$ 00.00
<b>SUBTOTAL 1</b> (SUM OF BID ITEM NOS. 1 THROUGH 5 FOR EACH RESPECTIVE DISTRICT)					\$ _____			\$ 00.00

FURNISHING AND DELIVERING METAL GUARDRAILS, POSTS, ELEMENT,  
 END TREATMENT SYSTEMS, HARDWARE AND IMPACT ATTENUATORS  
 PROJECT NO. HWY-C-03-23  
 ISLANDS OF OAHU AND MAUI  
**PROPOSAL SCHEDULE**

**2. RAIL ELEMENT, GALVANIZED STEEL, CORRUGATED GUARDRAIL, 3.81M (12'-6" O.C. WITH ADDITIONAL BOLT HOLE AT CENTER, INCLUDING BOLTS ATTENUATOR**

BID ITEM NO.	ITEM	BRAND/ITEM NO.	OAHU DISTRICT			MAUI DISTRICT		
			EST. YEARLY QTY. (EACH) (A)	UNIT PRICE (B)	AMOUNT (A x B)	EST. YEARLY QTY. (EACH) (C)	UNIT PRICE (D)	AMOUNT (C x D)
6	STRAIGHT RAIL ELEMENT (METAL W-BEAM SINGLE GALVANIZED GUARDRAIL), 12 GA x 12'-6", ( <i>Refer to Detail RWM04a, Sheet M-2, Appendix A of the Appendices</i> )		2,127	\$ _____	\$ _____	100	\$ _____	\$ _____
7	CONVEX. 9.15M (30') RADIUS FOR STRAIGHT RAIL ELEMENT		0	\$ 00.00	\$ 00.00	6	\$ _____	\$ _____
8	CONVEX. 18.29M (60') RADIUS FOR STRAIGHT RAIL ELEMENT		0	\$ 00.00	\$ 00.00	6	\$ _____	\$ _____
9	CONVEX. 21.34M (70') RADIUS FOR STRAIGHT RAIL ELEMENT		0	\$ 00.00	\$ 00.00	6	\$ _____	\$ _____
10	CONVEX. 30.49M (100') RADIUS FOR STRAIGHT RAIL ELEMENT		0	\$ 00.00	\$ 00.00	6	\$ _____	\$ _____

FURNISHING AND DELIVERING METAL GUARDRAILS, POSTS, ELEMENT,  
 END TREATMENT SYSTEMS, HARDWARE AND IMPACT ATTENUATORS

PROJECT NO. HWY-C-03-23  
 ISLANDS OF OAHU AND MAUI

**PROPOSAL SCHEDULE**

**2. (continuation) RAIL ELEMENT, GALVANIZED STEEL, CORRUGATED GUARDRAIL, 3.81M (12'-6" O.C. WITH  
 ADDITIONAL BOLT HOLE AT CENTER, INCLUDING BOLTS ATTENUATOR**

BID ITEM NO.	ITEM	BRAND/ITEM NO.	OAHU DISTRICT			MAUI DISTRICT		
			EST. YEARLY QTY. (EACH) (A)	UNIT PRICE (B)	AMOUNT (A x B)	EST. YEARLY QTY. (EACH) (C)	UNIT PRICE (D)	AMOUNT (C x D)
11	CONCAVE 9.15M (30') RADIUS FOR STRAIGHT RAIL ELEMENT		0	\$ 00.00	\$ 00.00	4	\$ _____	\$ _____
12	CONCAVE 18.29M (60') RADIUS FOR STRAIGHT RAIL ELEMENT		0	\$ 00.00	\$ 00.00	4	\$ _____	\$ _____
13	CONCAVE 21.34M (70') RADIUS FOR STRAIGHT RAIL ELEMENT		0	\$ 00.00	\$ 00.00	4	\$ _____	\$ _____
14	CONCAVE 30.49M (100') RADIUS FOR STRAIGHT RAIL ELEMENT		0	\$ 00.00	\$ 00.00	4	\$ _____	\$ _____
<b>SUBTOTAL 2</b> (SUM OF BID ITEM NOS. 6 THROUGH 14 FOR EACH RESPECTIVE DISTRICT)						\$ _____		\$ _____

FURNISHING AND DELIVERING METAL GUARDRAILS, POSTS, ELEMENT,  
 END TREATMENT SYSTEMS, HARDWARE AND IMPACT ATTENUATORS  
 PROJECT NO. HWY-C-03-23  
 ISLANDS OF OAHU AND MAUI  
**PROPOSAL SCHEDULE**

**3. GUARDRAIL HARDWARE**

BID ITEM NO.	ITEM	BRAND/ITEM NO.	OAHU DISTRICT			MAUI DISTRICT		
			EST. YEARLY QTY. (EACH) (A)	UNIT PRICE (B)	AMOUNT (A x B)	EST. YEARLY QTY. (EACH) (C)	UNIT PRICE (D)	AMOUNT (C x D)
15	GUARDRAIL GALVANIZED BACK-UP PLATES		1,587	\$ _____	\$ _____	0	\$ 00.00	\$ 00.00
16	5/8"x1.25" GALVANIZED GUARDRAIL SPLICE BOLT, BUTTON HEAD WITH RECESS NUT		19,000	\$ _____	\$ _____	0	\$ 00.00	\$ 00.00
17	5/8"x2" GALVANIZED GUARDRAIL POST BOLT, BUTTON HEAD WITH RECESS NUT		28,468	\$ _____	\$ _____	0	\$ 00.00	\$ 00.00
18	5/8"x10" GALVANIZED GUARDRAIL BOLT, BUTTON HEAD WITH RECESS NUT		8,000	\$ _____	\$ _____	0	\$ 00.00	\$ 00.00
19	5/8"x18" GALVANIZED GUARDRAIL BOLT, BUTTON HEAD WITH RECESS NUT		4,000	\$ _____	\$ _____	0	\$ 00.00	\$ 00.00

FURNISHING AND DELIVERING METAL GUARDRAILS, POSTS, ELEMENT,  
 END TREATMENT SYSTEMS, HARDWARE AND IMPACT ATTENUATORS  
 PROJECT NO. HWY-C-03-23  
 ISLANDS OF OAHU AND MAUI  
**PROPOSAL SCHEDULE**

**3. (continuation) GUARDRAIL HARDWARE**

BID ITEM NO.	ITEM	BRAND/ITEM NO.	OAHU DISTRICT			MAUI DISTRICT		
			EST. YEARLY QTY. (EACH) (A)	UNIT PRICE (B)	AMOUNT (A x B)	EST. YEARLY QTY. (EACH) (C)	UNIT PRICE (D)	AMOUNT (C x D)
20	5/8"x25" GALVANIZED GUARDRAIL BOLT, BUTTON HEAD WITH RECESS NUT		2,000	\$ _____	\$ _____	0	\$ 00.00	\$ 00.00
21	5/8" GALVANIZED WASHERS		0	\$ 00.00	\$ 00.00	0	\$ 00.00	\$ 00.00
<b>SUBTOTAL 3</b> (SUM OF BID ITEM NOS. 15 THROUGH 21 FOR EACH RESPECTIVE DISTRICT)					\$ _____			\$ 00.00

FURNISHING AND DELIVERING METAL GUARDRAILS, POSTS, ELEMENT,  
 END TREATMENT SYSTEMS, HARDWARE AND IMPACT ATTENUATORS  
 PROJECT NO. HWY-C-03-23  
 ISLANDS OF OAHU AND MAUI  
**PROPOSAL SCHEDULE**

**4. IMPACT ATTENUATOR**

BID ITEM NO.	ITEM	BRAND/ITEM NO.	OAHU DISTRICT			MAUI DISTRICT		
			EST. YEARLY QTY. (EACH) (A)	UNIT PRICE (B)	AMOUNT (A x B)	EST. YEARLY QTY. (EACH) (C)	UNIT PRICE (D)	AMOUNT (C x D)
22	INERTIAL BARRIER SYSTEM, "SAND BARREL", 700 LBS, WITH LID, WITHOUT SAND, WITH OR WITHOUT CONE INSERT		90	\$ _____	\$ _____	0	\$ 00.00	\$ 00.00
23	INERTIAL BARRIER SYSTEM, "SAND BARREL", 1400 LBS, WITH LID, WITHOUT SAND, WITH OR WITHOUT CONE INSERT		200	\$ _____	\$ _____	0	\$ 00.00	\$ 00.00
24	PERMANENT PLASTIC NOSE ASSEMBLY, YELLOW 36" (REGULAR WIDTH)		45	\$ _____	\$ _____	0	\$ 00.00	\$ 00.00
25	PLASTIC NOSE ASSEMBLY, YELLOW		45	\$ _____	\$ _____	0	\$ 00.00	\$ 00.00
26	DIAPHRAGM ASSEMBLY, 24" (610 MM)		25	\$ _____	\$ _____	0	\$ 00.00	\$ 00.00

FURNISHING AND DELIVERING METAL GUARDRAILS, POSTS, ELEMENT,  
 END TREATMENT SYSTEMS, HARDWARE AND IMPACT ATTENUATORS  
 PROJECT NO. HWY-C-03-23  
 ISLANDS OF OAHU AND MAUI  
**PROPOSAL SCHEDULE**

**4. (continuation) IMPACT ATTENUATOR**

BID ITEM NO.	ITEM	BRAND/ITEM NO.	OAHU DISTRICT			MAUI DISTRICT		
			EST. YEARLY QTY. (EACH) (A)	UNIT PRICE (B)	AMOUNT (A x B)	EST. YEARLY QTY. (EACH) (C)	UNIT PRICE (D)	AMOUNT (C x D)
27	DIAPHRAGM ASSEMBLY, 30" (753 MM)		45	\$ _____	\$ _____	0	\$ 00.00	\$ 00.00
28	DIAPHRAGM ASSEMBLY, 36" (913 MM)		25	\$ _____	\$ _____	0	\$ 00.00	\$ 00.00
29	DIAPHRAGM ASSEMBLY, 39" (993 MM)		25	\$ _____	\$ _____	0	\$ 00.00	\$ 00.00
30	DIAPHRAGM ASSEMBLY, 43" (1073 MM)		25	\$ _____	\$ _____	0	\$ 00.00	\$ 00.00
31	DIAPHRAGM ASSEMBLY, 46" (1153 MM)		25	\$ _____	\$ _____	0	\$ 00.00	\$ 00.00

FURNISHING AND DELIVERING METAL GUARDRAILS, POSTS, ELEMENT,  
 END TREATMENT SYSTEMS, HARDWARE AND IMPACT ATTENUATORS  
 PROJECT NO. HWY-C-03-23  
 ISLANDS OF OAHU AND MAUI  
**PROPOSAL SCHEDULE**

**4. (continuation) IMPACT ATTENUATOR**

BID ITEM NO.	ITEM	BRAND/ITEM NO.	OAHU DISTRICT			MAUI DISTRICT		
			EST. YEARLY QTY. (EACH) (A)	UNIT PRICE (B)	AMOUNT (A x B)	EST. YEARLY QTY. (EACH) (C)	UNIT PRICE (D)	AMOUNT (C x D)
32	DIAPHRAGM ASSEMBLY, 48" (1233 MM)		25	\$ _____	\$ _____	0	\$ 00.00	\$ 00.00
33	DIAPHRAGM ASSEMBLY, 51" (1273 MM)		25	\$ _____	\$ _____	0	\$ 00.00	\$ 00.00
34	CARTRIDGE ASSEMBLY		480	\$ _____	\$ _____	0	\$ 00.00	\$ 00.00
<b>SUBTOTAL 4</b> (SUM OF BID ITEM NOS. 22 THROUGH 34 FOR EACH RESPECTIVE DISTRICT)					\$ _____			\$ 00.00

FURNISHING AND DELIVERING METAL GUARDRAILS, POSTS, ELEMENT,  
 END TREATMENT SYSTEMS, HARDWARE AND IMPACT ATTENUATORS  
 PROJECT NO. HWY-C-03-23  
 ISLANDS OF OAHU AND MAUI

BID SUMMARY

	OAHU DISTRICT	MAUI DISTRICT
SUBTOTAL 1	\$ _____	\$ 00.00
SUBTOTAL 2	\$ _____	\$ _____
SUBTOTAL 3	\$ _____	\$ 00.00
SUBTOTAL 4	\$ _____	\$ 00.00
SUM OF SUBTOTALS FOR EACH DISTRICT	\$ _____	\$ _____

<b>TOTAL AMOUNT FOR COMPARISON OF BIDS</b>	\$ _____
--	----------

FURNISHING AND DELIVERING METAL GUARDRAILS, POSTS, ELEMENT,  
END TREATMENT SYSTEMS, HARDWARE AND IMPACT ATTENUATORS  
PROJECT NO. HWY-C-03-23  
ISLANDS OF OAHU AND MAUI

Bidder shall refer to the following notes:

“The attention of out-of-state bidders is directed to Section 2.8 of the Specifications. An out-of-state bidder is required to answer the following statement:

State of Hawaii General Excise and Use Taxes are included in all bid prices.

---

Write “Yes” or “No”

If the above statement is left unanswered, it will be considered a “No” answer by the State.”

---

NOTES:

1. Bids shall include all Federal, State, County and other applicable taxes and fees.
2. The TOTAL AMOUNT FOR COMPARISON OF BIDS will be used to determine the lowest responsible bidder.
3. Bidders shall complete all unit prices and amounts. Failure to do so may be grounds for rejection of bid.
4. If a discrepancy occurs between unit bid price and the bid price, the unit bid price shall govern.
5. Bidders shall make no changes to the items in the Proposal Schedule. Altered Proposal Schedules shall be rejected. Only provide bid prices and totals where space is provided. Bidder is required to bid on all items.
6. The number of estimated maximum yearly quantities in the Proposal Schedule is for bidding purpose only. Payments to the Contractor will be made based on actual number of deliveries and the unit bid price.
7. By Submitting a proposal, the Bidder acknowledges he has read and understands all the provisions of the Special Provisions and the Specifications and is fully aware of all the conditions to be encountered in performing the work.
8. The materials for this contract shall be furnished on an “as-needed” basis as required by the State. The estimated quantities specified do not signify a maximum or minimum quantity.

FURNISHING AND DELIVERING METAL GUARDRAILS, POSTS, ELEMENT,  
END TREATMENT SYSTEMS, HARDWARE AND IMPACT ATTENUATORS  
PROJECT NO. HWY-C-03-23  
ISLANDS OF OAHU AND MAUI

NOTES (cont'd):

9. Completed proposal file shall be uploaded into HiePRO prior to the bid opening date and time. All other required confidential proprietary documents shall be uploaded separately.
10. Prior to award, the contractor is required to submit documents as specified in Section 10.6(G).

STATE OF HAWAII  
DEPARTMENT OF TRANSPORTATION  
HONOLULU, HAWAII

F O R M S

Contents:

Contract

C O N T R A C T

THIS AGREEMENT, made this day \_\_\_\_\_, by and between the STATE OF HAWAII, by its Director of Transportation, hereinafter referred to as "STATE", and «CONTRACTOR», «STATE\_OF\_INCORPORATION», whose business and/or mailing address is «ADDRESS», hereinafter referred to as CONTRACTOR";

WITNESSETH: That for and in consideration of the payments hereinafter mentioned, the CONTRACTOR hereby covenants and agrees with the STATE to complete in place, furnish and pay for all labor and materials necessary for "«PROJECT\_NAME\_AND\_NO»", or such a part thereof as shall be required by the STATE, the total amount of which labor, material and construction shall be computed at the unit and/or lump sum prices set forth in the attached proposal schedule and shall be the sum of «BASIC»-----DOLLARS (\$«BASIC\_NUMERIC») as follows:

TOTAL AMOUNT FOR COMPARISON OF BIDS .....\$«BASIC\_NUMERIC»

which sum shall be provided from STATE funds, all in accordance with the specifications, the special provisions, if any, the notice to bidders, the instructions to bidders, the proposal and plans for «PROJECT NO ONLY» and any supplements thereto, on file in the office of the Director of Transportation. These documents, together with all alterations, amendments, and additions thereto and deductions therefrom, are attached hereto or incorporated herein by reference and made a part of this contract.

The CONTRACTOR hereby covenants and agrees to complete such work from the date indicated in the Notice to Proceed issued by the STATE within «WORKING DAYS», subject, however, to such extensions as may be provided for in writing under the specifications.

For and in consideration of the covenants, undertakings and agreements of the CONTRACTOR herein set forth and upon the full and faithful performance thereof by the CONTRACTOR, the STATE hereby agrees to pay the CONTRACTOR the sum of «BASIC»-----DOLLARS (\$«BASIC NUMERIC») in lawful money, but not more than such part of the same as is actually earned according to the STATE's determination of the actual quantities of work performed and materials furnished by the CONTRACTOR at the unit or lump sum prices set forth in the attached proposal schedule. Such payment, including any extras, shall be made, subject to such additions or deductions hereto or hereafter made in the manner and at the time prescribed in the specifications and this contract. An additional sum of -----«EXTRAS»----- «STATE EXTRAS»DOLLARS (\$«EXTRA NUMERIC») is hereby provided for extra work and shall be provided from State funds.

All words used herein in the singular shall extend to and include the plural. All words used in the plural shall extend to and include the singular. The use of any gender shall extend to and include all genders.

IN WITNESS WHEREOF, the parties hereto have caused this instrument to be duly executed the day and year first above written.

STATE OF HAWAII

\_\_\_\_\_  
Director of Transportation

«CONTRACTOR»

\_\_\_\_\_  
Signature

\_\_\_\_\_  
Print name

\_\_\_\_\_  
Print Title

\_\_\_\_\_  
Date